

EVOLINE<sup>3</sup>

# INDEX

## SPORTELLO FILOMURO

FLUSH WALL SWING PANEL

VANTAIL AFFLEURANT

WANDBÜNDIGE KABINENTÜRE

Descrizione capitolato	78
Specifications	78
Sportello filomuro > versi di apertura	79
Flush Wall Swing Panel > Opening directions	79
Sportello filomuro > componenti dello sportello	80
Flush Wall Swing Panel > Components	80
Sportello filomuro > per muratura > telaio 3 lati	81
Flush Wall Swing Panel > for a brick wall > frame on 3 sides	81
Sportello filomuro > per muratura > telaio 4 lati	82
Flush Wall Swing Panel > for a brick wall > frame on 4 sides	82
Sportello filomuro > per cartongesso > telaio 3 lati	83
Flush Wall Swing Panel > for a plasterboard wall > frame on 3 sides	83
Sportello filomuro > per cartongesso > telaio 4 lati	84
Flush Wall Swing Panel > for a plasterboard wall > frame on 4 sides	84
Sportello filomuro	85
Flush Wall Swing Panel	85
Sportello filomuro > esempi aperture realizzabili	86
Flush Wall Swing Panel > Examples of the feasible openings	86
Vista assonometrica	87
Perspective view	87
Sportello filomuro > telaio porta	88
Flush Wall Swing Panel > door frame	88
Sportello filomuro > pannello porta	
Flush Wall Swing Panel > door panel	
- finitura: trattamento di fondo	89
- finish: primed	89
- finitura: laccatura opaca / uniformemente sabbiato	90
- finish: matt lacquering / uniforming treatment sandblasted	90
Sportello filomuro > maniglia ricavata	91
Flush Wall Swing Panel > Built-In Handle	91
Sportello filomuro > listino prezzi	92
Flush Wall Swing Panel > Price list	92
Sportello filomuro > come definire le specifiche	93
Flush Wall Swing Panel > how to define the specifications	93

# SPORTELLO FILOMURO

## FLUSH WALL SWING PANEL

### VANTAIL AFFLEURANT

### WANDBÜNDIGE KABINENTÜRE

DESCRIZIONE CAPITOLATO / SPECIFICATIONS / DESCRIPTION / BESCHREIBUNG

Lo sportello a battente filomuro EVOLINE<sup>3</sup>, ispirato ad un design minimale e moderno, si contraddistingue per l'utilizzo di un telaio in alluminio lega 6060-T6 preverniciato a polveri RAL 9003 da inserire direttamente nelle pareti di muratura o di cartongesso, eliminando totalmente cornici e coprifili in legno. Lo sportello si presta a soddisfare molteplici esigenze. Può fungere da anta per le cabine armadio o da copertura di vani di centrali elettriche ed idrauliche, o più in generale di nicchie che si desidera celare o utilizzare in altro modo. Una volta installato, il telaio è pronto per essere tonalizzato come le pareti con vernici murali. In alternativa, il telaio può essere lasciato al naturale, poiché preverniciato di colore bianco. Il telaio, nell'unica versione a tirare, è di semplice e veloce installazione. La presenza di zanche e reti, nel caso del telaio per muratura, e di profilo aggiunto, nel caso del telaio per cartongesso, permette di ottenere il miglior risultato durante l'installazione. Squadri e distanziali in legno e alluminio consentono di mantenere il telaio sempre allineato, evitando deformazioni durante il trasporto e l'installazione. A seguito del montaggio del telaio andranno otturati i forellini che si presenteranno dopo la rimozione dei distanziali. Un'ulteriore peculiarità tecnica è rappresentata dall'utilizzo di

The flush wall swing panel EVOLINE<sup>3</sup> has an essential and modern design. Its distinctive feature is the use of a pre-painted aluminium frame that can be mounted directly into a brick or a plasterboard wall, eliminating cover profiles and visible jambs, creating perfect continuity of wall and door. The swing panels have several, diversified applications. They can be used to cover electric and hydraulic panels or other niches the customer would like to hide. Once installed, the frame can be painted the same colour of the wall or it can be used in its original white colour. The frame is made in the only version to pull and its mounting is simple and fast. In case of a brickwall, the frame has additional nets and clamps which help to get the best result in the mounting. In case of a plasterboard wall, the frame has an additional profile which guarantees the result. To avoid deformation during delivery and installing the frame is kept aligned by spacers, which can be removed once the frame has been mounted. The little holes left by the removal of the spacers can be filled with plaster. The flush wall swing panel EVOLINE<sup>3</sup> has concealed, adjustable hinges, which allow a

Le vantail à battant EVOLINE<sup>3</sup> s'uniformise parfaitement avec le cloison et se caractérise par l'utilisation d'un châssis pré-vernicié en aluminium à insérer directement dans le mur de maçonnerie ou placoplâtre. Le vantail EVOLINE<sup>3</sup> a été élaboré pour satisfaire exigences différentes, comme le camouflage des tableaux électriques et des canalisations ou la fermeture des niches. Il peut aussi être utilisé pour débarras et armoires. Après le montage le châssis peut être vernicié de la même couleur du mur ou il peut être maintenu en le couleur blanc original. Le châssis est dans la seule option à tirer; son installation est simple et rapide: un profil supplémentaire fixé sur le profil EVOLINE<sup>3</sup> standard permet l'installation sur mur en placoplâtre. En cas de mur en maçonnerie les agrafes en acier permettent l'ancrage du châssis au mur. Entretoises maintiennent le châssis aligné pour éviter la déformation durant le montage ou durant le livraison. L'entretoises peuvent être retirés après le montage et les trous remplis de mastic. Une autre particularité technique du vantail affleurant EVOLINE<sup>3</sup> est qu'il est fourni avec des charnières escamotables et réglables pour un parfait calibrage de la lumière périmétrale. Le vantail

Die wandbündige Kabinentür EVOLINE<sup>3</sup> zeichnet sich durch ein modernes, minimalistisches Design und besonders durch die Verwendung eines vorgestrichenen Aluminium Rahmen, der direkt in eine Gipskarton- oder Mauerwand montiert wird, aus. Durch dieses System werden sichtbare Rahmen und Rahmenverkleidungen unnötig. Für die Kabinentüre EVOLINE<sup>3</sup> gibt es zahlreiche, unterschiedliche Verwendungsmöglichkeiten: Sie eignet sich als Abdeckung für Strom- oder Wasserzähler und für all die Nischen, die man gerne verstecken möchte. Die Kabinentüre kann sowohl auch als Türe für Wandschränke oder Kleiderräume verwendet werden. Nach dem Einbau kann der Rahmen in der Farbe der Wand gestrichen werden, oder das vorgestrichene weiße Standardprofil kann beibehalten werden. Der Rahmen ist nur in der Version zum Ziehen erhältlich und seine Montage ist einfach und schnell. Bei Gipskartonwänden ist ein zusätzliches Profil, das am Standard-Rahmen befestigt ist, für den Einbau notwendig. Bei Mauerwänden werden Lochgitterstreifen verwendet, die die Verankerung des Rahmens in der Wand ermöglichen. Um Verformungen des Profils während dem Transport und dem Einbau zu vermeiden werden Distanzstücke benutzt. Nachdem der Rahmen montiert ist können die, von der Entfernung der Distanzstücke gebliebenen Löcherlein, mit Kitt gefüllt werden. Eine weitere technische Eigenschaft der Kabinentüre

cerniere regolabili e scomparsa, che consentono una perfetta calibrazione della luce tra telaio e pannello. L'apertura e chiusura avviene mediante il premi/apri incassato nel telaio. A seconda delle esigenze specifiche è possibile variare il sistema di chiusura utilizzando chiusura a calamita o chiusura a rullino. Il pannello tamburato ha uno spessore di 35 mm ed è realizzato con materiali di prima scelta e con mdf da 5 mm. Il pannello viene fornito con trattamento di fondo per facilitare le successive applicazioni di vernici murali o altri tipi di applicazioni. E' inoltre possibile richiedere il pannello laccato opaco o uniformante sabbiato. Telaio e pannello sono identificati da un numero di matricola per consentirne la rintracciabilità nel caso di consegne separate e per facilitare l'assistenza post vendita.

#### IN SINTESI

- telaio alluminio lega 6060-T6 preverniciato a polveri RAL 9003
- cerniere a scomparsa regolabili 3D
- premi/apri
- pannello spessore mm 35

perfect light calibration between frame and panel. The standard panel has a push/open lock mounted onto the frame. On request can be provided other opening systems, as magnetick lock or a spool lock. The timbered, 35mm-thick panel is made of a 5mm-thick MDF layer and of other selected materials. The panels are provided with a priming treatment that eases the following paintings. The panels can also be matt lacquered or with an uniforming treatment sandblasted. The panel and the frame are identified by an identification number to make them easily traceable when separatly delivered and to simplify post-sale assistance.

#### SUMMARIZING:

- pre-painted aluminium frame in aluminum alloy 6060-T6, in a powder-prepainting colour RAL 9003
- adjustable, concealed hinges
- push/open lock
- 35mm thick panel

standard a une serrure encastrée dans le montant mural. Sur demande il est possible de avoir un'autre système d'ouverture comme un aimant ou un rouleau. Le panneau en bois de 35 mm est réalisé avec une plaque MDF de 5 mm et d'autres matériaux sélectionnés. Le panneau du vantail est pré-peint, pour faciliter les suivantes applications de la peinture murale ou d'autres typologies d'applications. Il est aussi possible de commander le panneau avec le laquage mat ou avec un traitement uniformisant sablé. Les produits EVOLINE<sup>3</sup> sont marqués par une matrice unique qui permet de les identifier facilement en cas de livraison séparée ou pour l'assistance après vente.

#### RÉSUMÉ:

- un châssis pré-vernicié d'aluminium 6060-T6, pré-peint à poudre en RAL 9003
- charnières escamotables et réglables
- une serrure magnétique
- un panneau de 35 mm d'épaisseur

EVOLINE<sup>3</sup> ist die Verwendung versenkter, registrierbarer Scharniere, die eine perfekte Kalibrierung des Lichtes zwischen Rahmen und Türblatt erlauben. Die Standard-Türöffnung erfolgt durch ein "Drücken-öffnen"-Schloß das in dem Rahmen eingelassen ist. Je nach den persönlichen Erfordernissen können auch andere Schlosssysteme eingebaut werden, wie z. Bsp. ein Magnet oder eine Rollfalle. Das 35mm dicke Sperrholz-Türblatt besteht aus einer 5mm-dicken MDF-Schicht und anderen ausgewählten Materialien. Das Türblatt kan roh oder mit einer Grundierung, die die folgenden Bearbeitungen erleichtert, bestellt werden. Außerdem kann der Kunde die Türblätter in Mattlackiert oder mit einer einheitlichen Behandlung (sandgestrahlt) bestellt werden. Eine Matrikelnummer identifiziert den Rahmen und das Türblatt, um die Rückverfolgbarkeit der Ware im Fall getrennter Lieferungen zu erleichtern und um die beste Kundenbetreuung zu ermöglichen.

#### ZUSAMMENFASSUNG

- vorgestrichener Aluminiumrahmen aus Legierung 6060-T6, pulverbeschichtet in RAL 9003
- regulierbare versenkte Scharniere
- Drücken-öffnen-Schloß
- 35mm dickes Türblatt

**SPORTELLO FILOMURO**  
 FLUSH WALL SWING PANEL  
 VANTAIL AFFLEURANT  
 WANDBÜNDIGE KABINENTÜRE

VERSI DI APERTURA / OPENING DIRECTIONS/  
 TYPOLOGIES D'OUVERTURE/ ÖFFNUNGSRICHTUNG

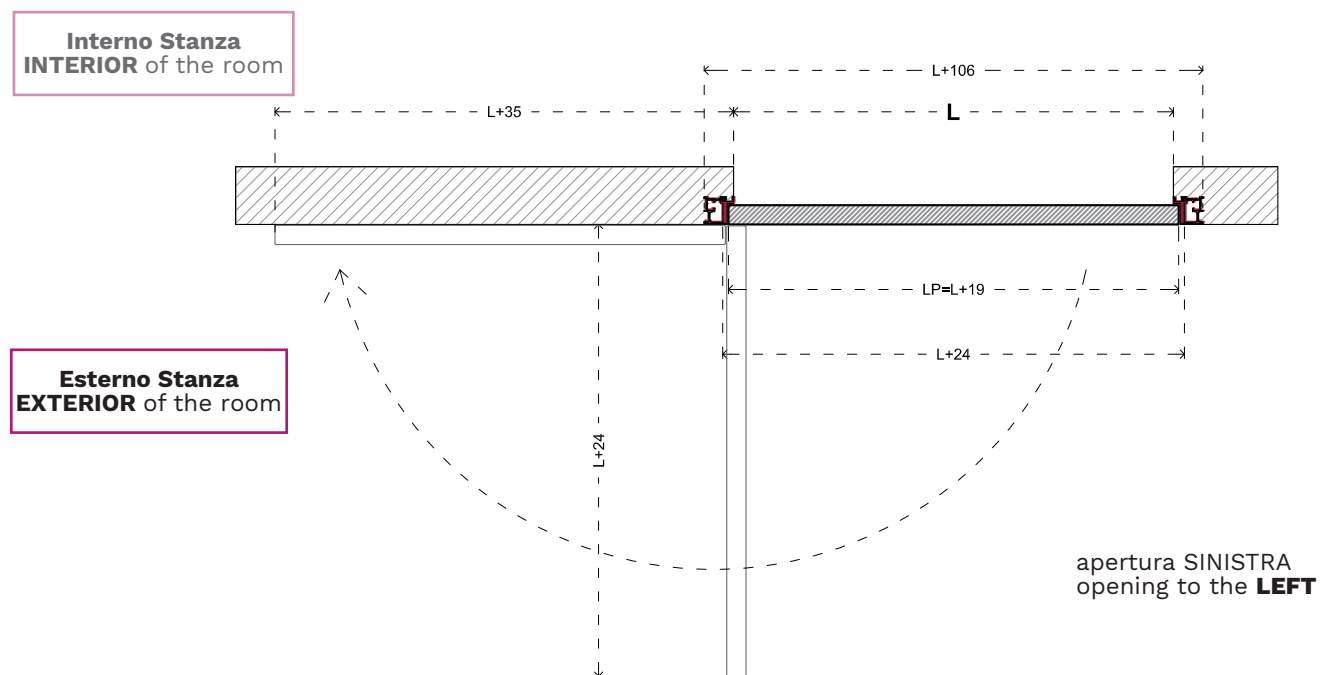
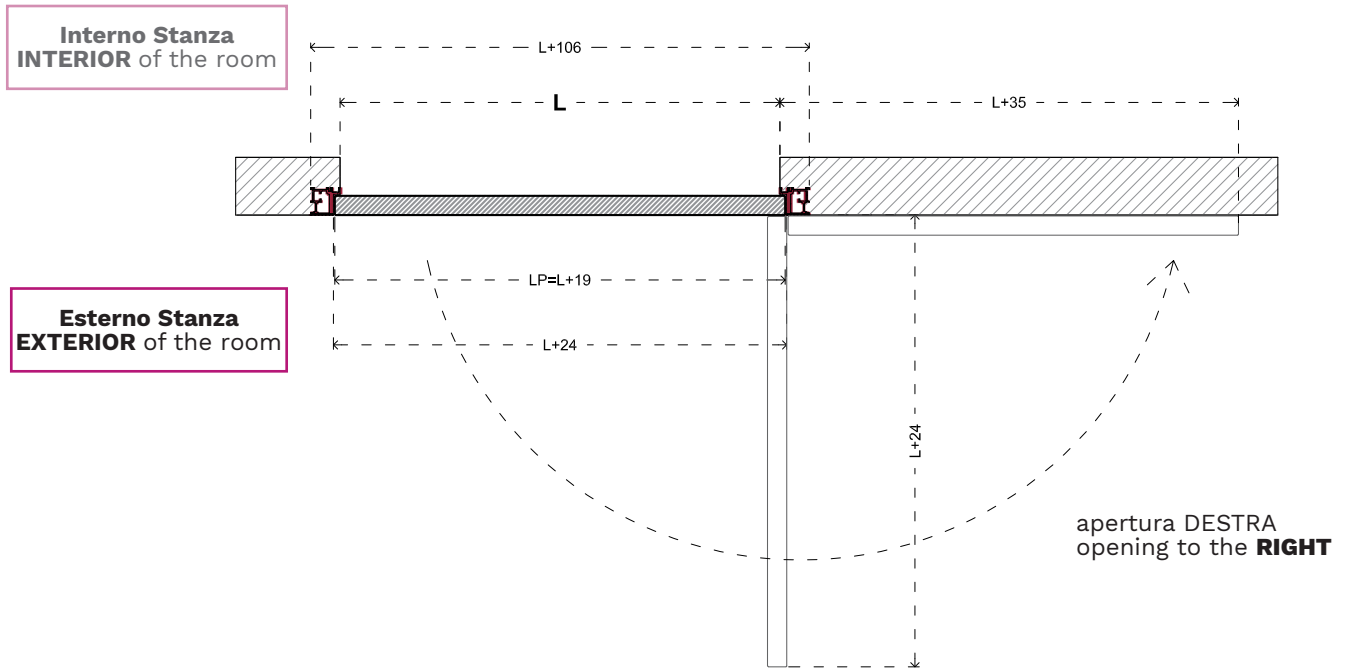

# SPORTELLO FILOMURO

## FLUSH WALL SWING PANEL

### VANTAIL AFFLEURANT

### WANDBÜNDIGE KABINENTÜRE

COMPONENTI DELLO SPORTELLO / COMPONENTS OF THE FLUSH WALL SWING PANEL / ÉLÉMENTS  
COMPOSANTS DU VANTAIL / TÜRELEMENTE DER KABINENTÜRE



#### COMPONENTI DEL TELAIO STANDARD SU MURATURA

- telaio in alluminio lega 6060-T6 preverniciato a polveri RAL 9003 assemblato con distanziali
- rete angolare forata applicata al telaio lato interno stanza
- zanche da aprire applicate al telaio

#### COMPONENTI DEL TELAIO STANDARD SU CARTONGESSO

- telaio in alluminio lega 6060-T6 preverniciato a polveri RAL 9003 assemblato con distanziali
- profilo aggiunto per cartongesso applicato al telaio

#### COMPONENTI ANTA STANDARD

- anta con finitura richiesta nell'ordine
- viti autofilettanti per premi/apri
- cerniere a scomparsa bianche/cromo opaco
- viti per cerniere (lato telaio)
- viti per cerniere (lato pannello)
- Lo sportello è identificato da un numero di matricola posto nella cava cerniera sul telaio
- I componenti sfusi (cerniere, viti, serratura, ecc....) sono contenuti in una scatola all'interno dell'imballo del pannello



#### COMPONENTS OF THE STANDARD FRAME FOR A BRICKWALL:

- aluminum frame made in aluminum alloy 6060-T6, in a powder-prepainting colour RAL 9003, kept aligned by removeable spacers
- perforated net applied to the internal side of the frame
- steel brackets applied to the frame

#### COMPONENTS OF THE STANDARD FRAME FOR A PLASTERBOARD WALL:

- pre-painted aluminium frame kept aligned by removeable spacers
- additional jamb fixed to the standard EVOLINE<sup>3</sup> frame

#### COMPONENTS OF THE STANDARD PANEL:

- panel in the required finishing
- push/open door lock to be installed
- self-tapping screws
- concealed hinges white/matt chrom
- screws for the hinges (on the side of the frame)
- screws for the hinges (on the side of the panel)
- A matrix written in the hinge hole on the frame identifies the panels
- Small components (screws, hinges and door handle) are delivered in a box inside the panel package



#### ÉLÉMENTS DU CHÂSSIS STANDARD POUR MUR EN MAÇONNERIE

- châssis en alliage d'aluminium 6060-T6, pré-peint à poudre en RAL 9003, assemblé avec des entretoises amovibles
- grillage perforé appliqué sur le côté intérieur du châssis
- agrafes d'acier appliqué sur le châssis

#### ÉLÉMENTS DU CHÂSSIS STANDARD POUR MUR EN PLACOPLÂTRE

- châssis pré-verni en aluminium assemblé avec entretoises amovibles
- profil de direction appliqué sur le châssis EVOLINE<sup>3</sup> standard

#### ÉLÉMENTS DU PANNEAU VANTAIL STANDARD

- panneau avec la finition demandée
- vis autotaraudeuses pour le serrure pousse/ouvre
- charnières invisibles blanches/chrome matte
- vis pour les charnières (côté du châssis)
- vis pour les charnières (côté du panneau)
- Le Vantail EVOLINE<sup>3</sup> est identifié par une matrice écrite dans la cavité des charnières sur le châssis
- Vis, charnières et poignée sont livrés dans une boîte, que se trouve à l'intérieur de l'emballage



#### KOMPONENTEN DES STANDARD-RAHMEN FÜR MAUERWAND

- vorgestrichener Aluminiumrahmen aus Legierung 6060-T6, pulverbeschichtet in RAL 9003 mit entfernbaren Distanzstücken zusammengebaut
- gelochtes Ecknetz, auf Rahmen montiert, im Innenraum
- Lochgitterstreifen auf Rahmen montiert

#### KOMPONENTEN DES STANDARD-RAHMEN FÜR GIPSKARTONWAND

- vorgestrichener Aluminiumrahmen mit entfernbaren Distanzstücken
- zusätzliches Profil, auf Standard-Rahmen fixiert

#### KOMPONENTEN DES STANDARD-TÜRBLATTES

- Türblatt in der erfragten Ausführung
- Selbstschneidende Schrauben
- Versenkte Scharniere in weiss/mattchrom
- Schrauben für Scharniere (für Rahmenseite)
- Schrauben für Scharniere (für Türblattseite)
- Eine Matrikelnummer, die im Scharnierloch des Rahmens angegeben ist, identifiziert die Kabinentür
- Schrauben, Türschloss und Scharniere werden zusammen in einer Schachtel im Karton des Türblattes verpackt

SPORTELLO FILOMURO > PER MURATURA > TELAIO 3 LATI  
 FLUSH WALL SWING PANEL > FOR BRICKWALL > FRAME ON 3 SIDES  
 VANTAIL AFFLEURANT > POUR MAÇONNERIE > CHÂSSIS SUR 3 CÔTÉS  
 WANDBÜNDIGE KABINETTÜRE > FÜR MAUERWAND > 3-SEITIGER RAHMEN

POSIZIONAMENTO - INGOMBRI / POSITIONING - ENCUMBRANCE /  
 POSITIONNEMENT - ENCOMBREMENT / POSITIONIERUNG - GESAMTMASS

SEZIONE VERTICALE - VERTICAL SECTION

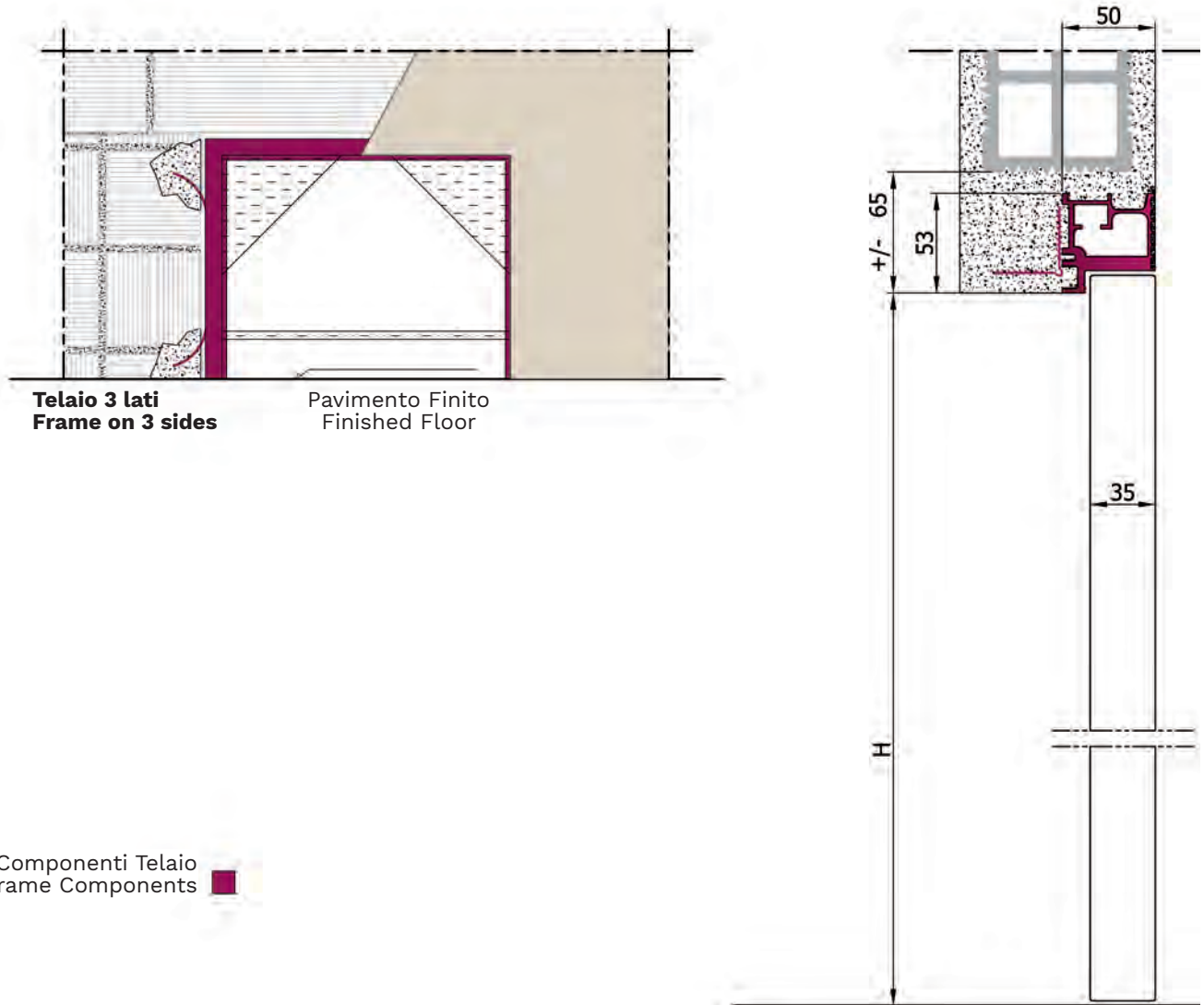

SEZIONE ORIZZONTALE - HORIZONTAL SECTION

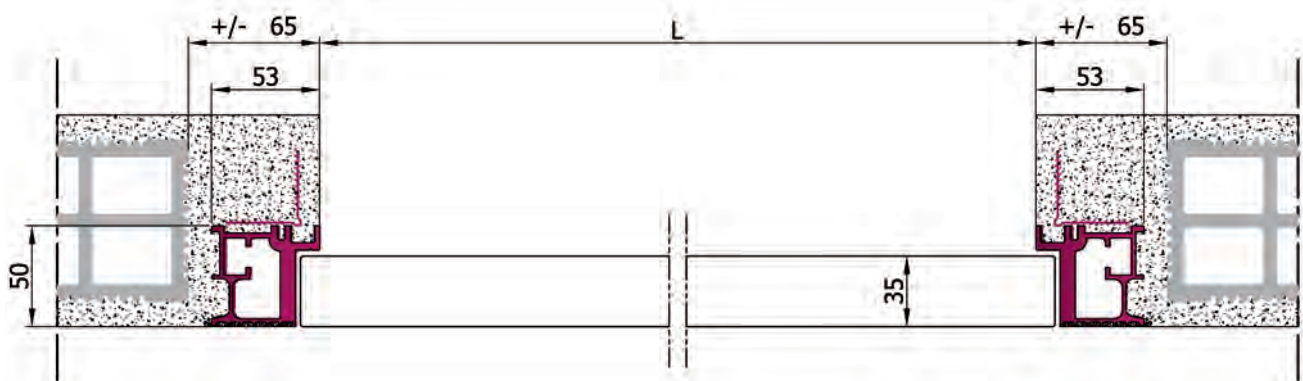

SPORTELLO FILOMURO > PER MURATURA > TELAIO 4 LATI  
 FLUSH WALL SWING PANEL > FOR BRICKWALL > FRAME ON 4 SIDES  
 VANTAIL AFFLEURANT > POUR MAÇONNERIE > CHÂSSIS SUR 4 CÔTÉS  
 WANDBÜNDIGE KABINETTÜRE > FÜR MAUERWAND > 4-SEITIGER RAHMEN

POSIZIONAMENTO - INGOMBRI / POSITIONING - ENCUMBRANCE / POSITIONNEMENT - ENCOMBREMENT / POSITIONIERUNG - GESAMTMASS

SEZIONE VERTICALE - VERTICAL SECTION

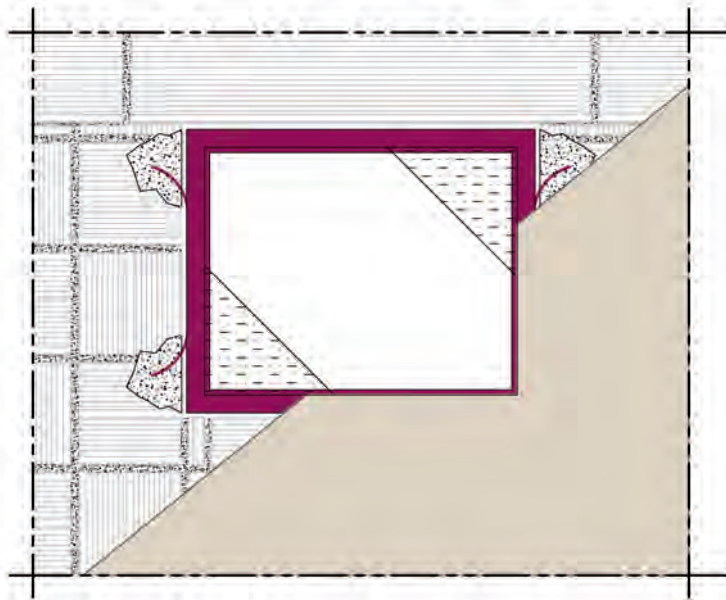

Telaio 3 lati  
 Frame on 3 sides

Componenti Telaio  
 Frame Components

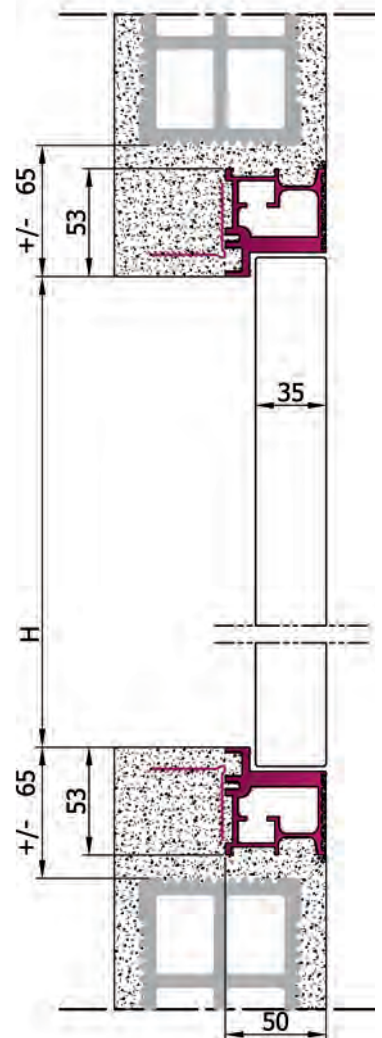

SEZIONE ORIZZONTALE - HORIZONTAL SECTION

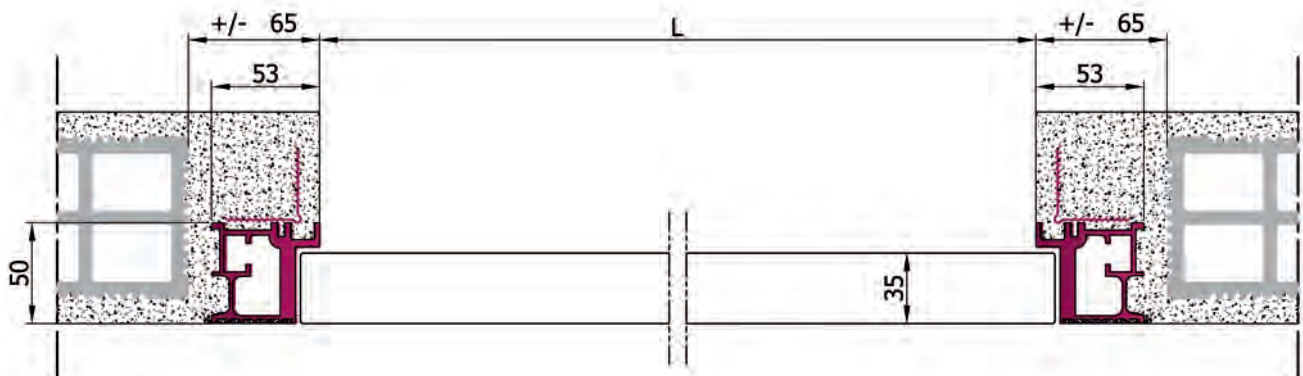

SPORTELLO FILOMURO > PER CARTONGESSO > TELAIO 3 LATI  
 FLUSH WALL SWING PANEL > FOR BRICKWALL > FRAME ON 3 SIDES  
 VANTAIL AFFLEURANT > POUR MAÇONNERIE > CHÂSSIS SUR 3 CÔTÉS  
 WANDBÜNDIGE KABINETTÜRE > FÜR MAUERWAND > 3-SEITIGER RAHMEN

POSIZIONAMENTO - INGOMBRI / POSITIONING - ENCUMBRANCE /  
 POSITIONNEMENT - ENCOMBREMENT / POSITIONIERUNG - GESAMTMASS

SEZIONE VERTICALE - VERTICAL SECTION

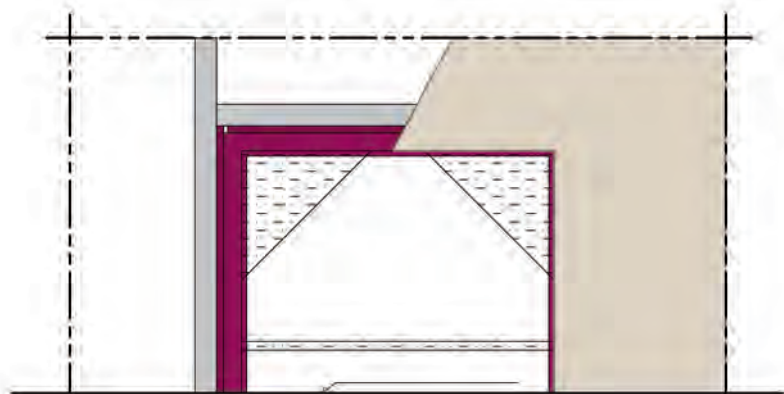

Telaio 3 lati  
 Frame on 3 sides

Pavimento Finito  
 Finished Floor

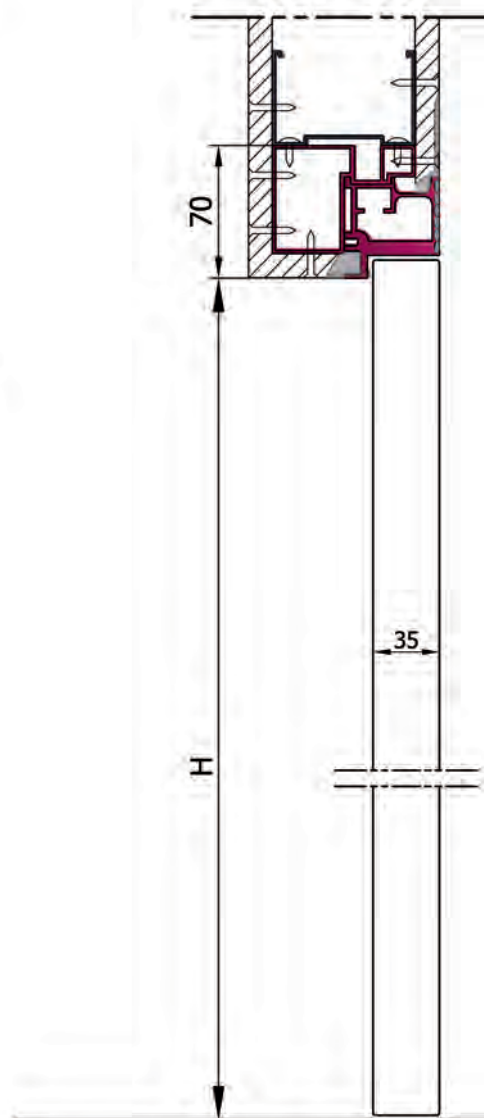

Componenti Telaio  
 Frame Components



SEZIONE ORIZZONTALE - HORIZONTAL SECTION

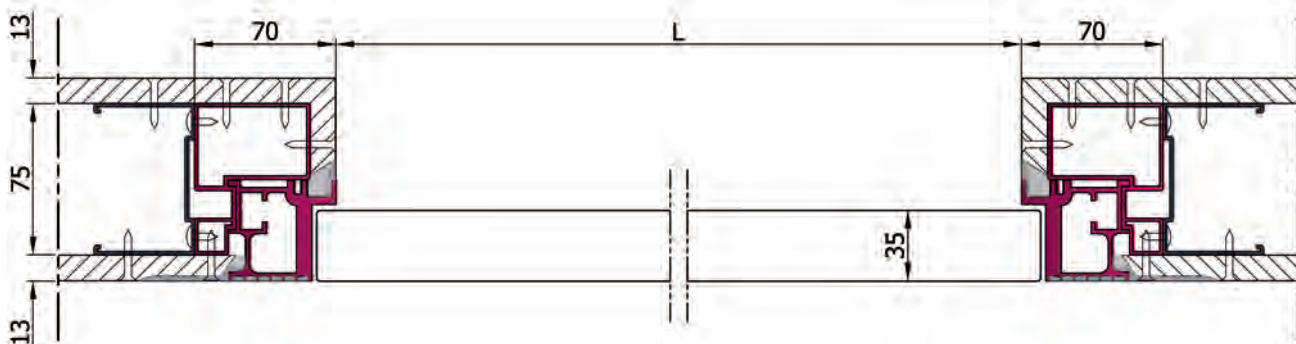



## SPORTELLO FILOMURO > PER CARTONGESSO > TELAIO 4 LATI

FLUSH WALL SWING PANEL > FOR PLASTERBOARD WALL > FRAME ON 4 SIDES

VANTAIL AFFLEURANT > POUR PLACOPLÂTRE > CHÂSSIS SUR 4 CÔTÉS

WANDBÜNDIGE KABINETTÜRE > FÜR GIPSKARTONWAND > 4-SEITIGER RAHMEN

POSIZIONAMENTO - INGOMBRI / POSITIONING - ENCUMBRANCE /

POSITIONNEMENT - ENCOMBREMENT / POSITIONIERUNG - GESAMTMASS

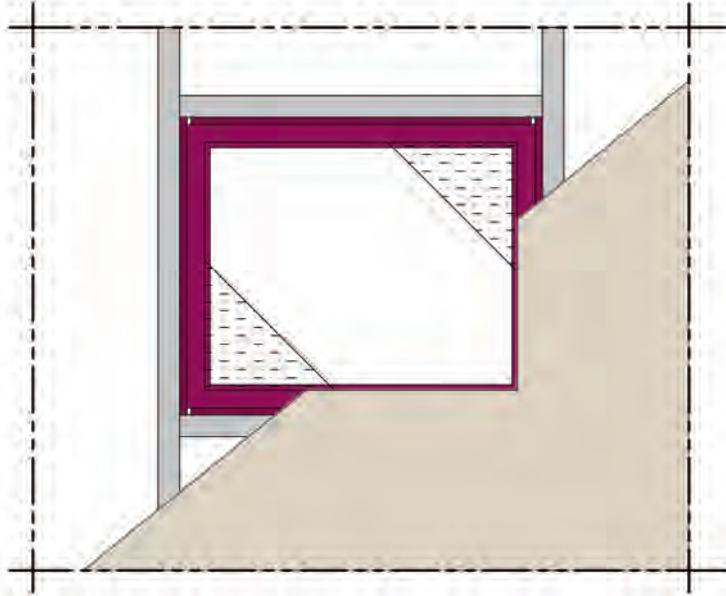

**Telaio 4 lati**  
**Frame on 4 sides**

Componenti Telaio  
Frame Components



### SEZIONE VERTICALE - VERTICAL SECTION

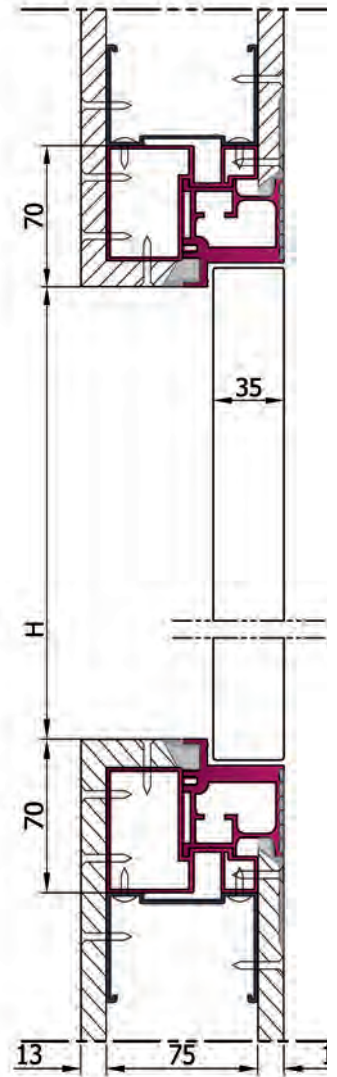

### SEZIONE ORIZZONTALE - HORIZONTAL SECTION

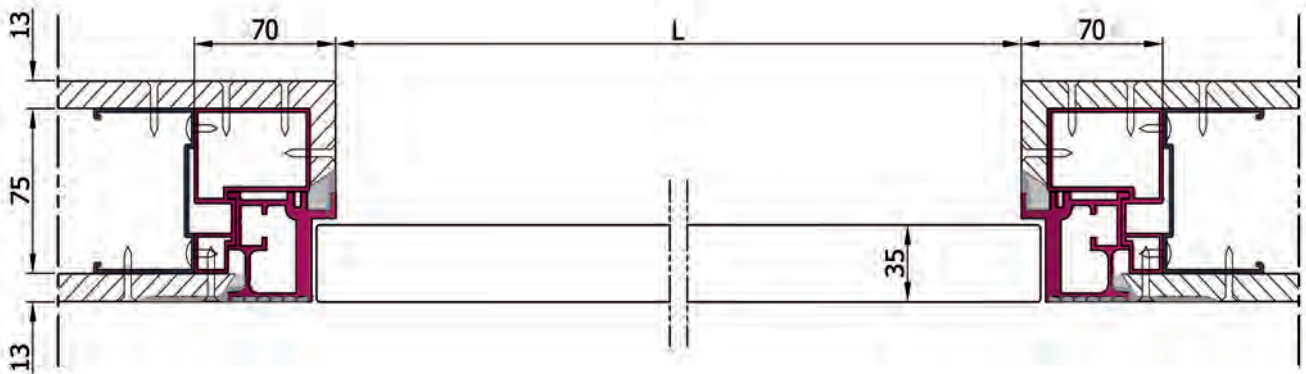

**SPORTELLO FILOMURO**  
 WANDBÜNDIGE KABINETTÜRE  
 VANTAIL AFFLEURANT  
 FLUSH WALL SWING PANE

SEZIONE SCALA 1:2 / DRAWING IN SCALE 1:2 / ECHELLE 1:2 / MASSSTAB 1:2

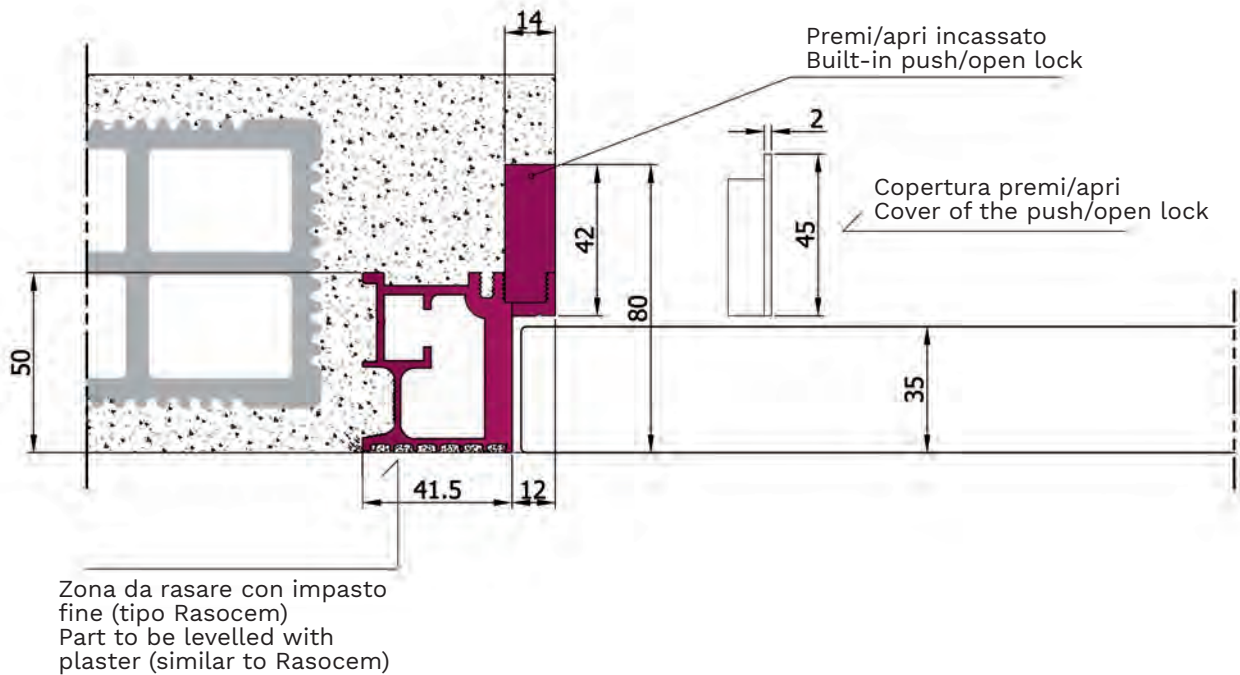
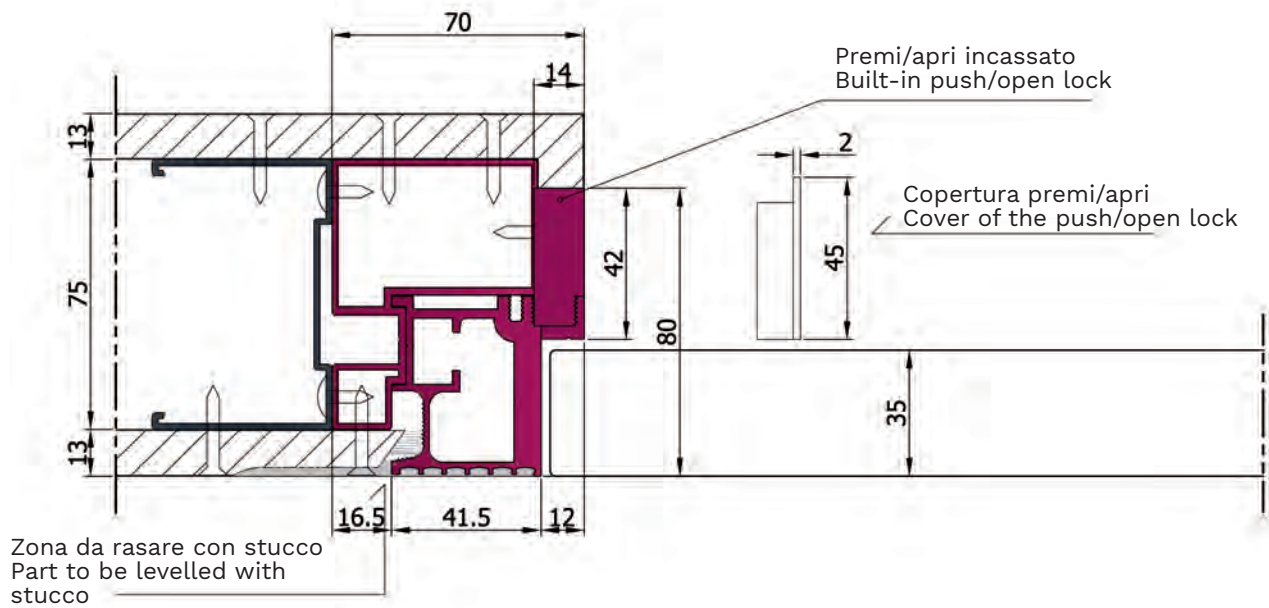

**SPORTELLO FILOMURO**  
**WANDBÜNDIGE KABINETTÜRE**  
**VANTAIL AFFLEURANT**  
**FLUSH WALL SWING PANEL**

ESEMPI DI APERTURE REALIZZABILI / EXAMPLES OF OPENINGS /  
 EXEMPLES DES POSSIBLES TYPOLOGIES D'OUVERTURE / BEISPIELE DER MÖGLICHEN ÖFFNUNGEN

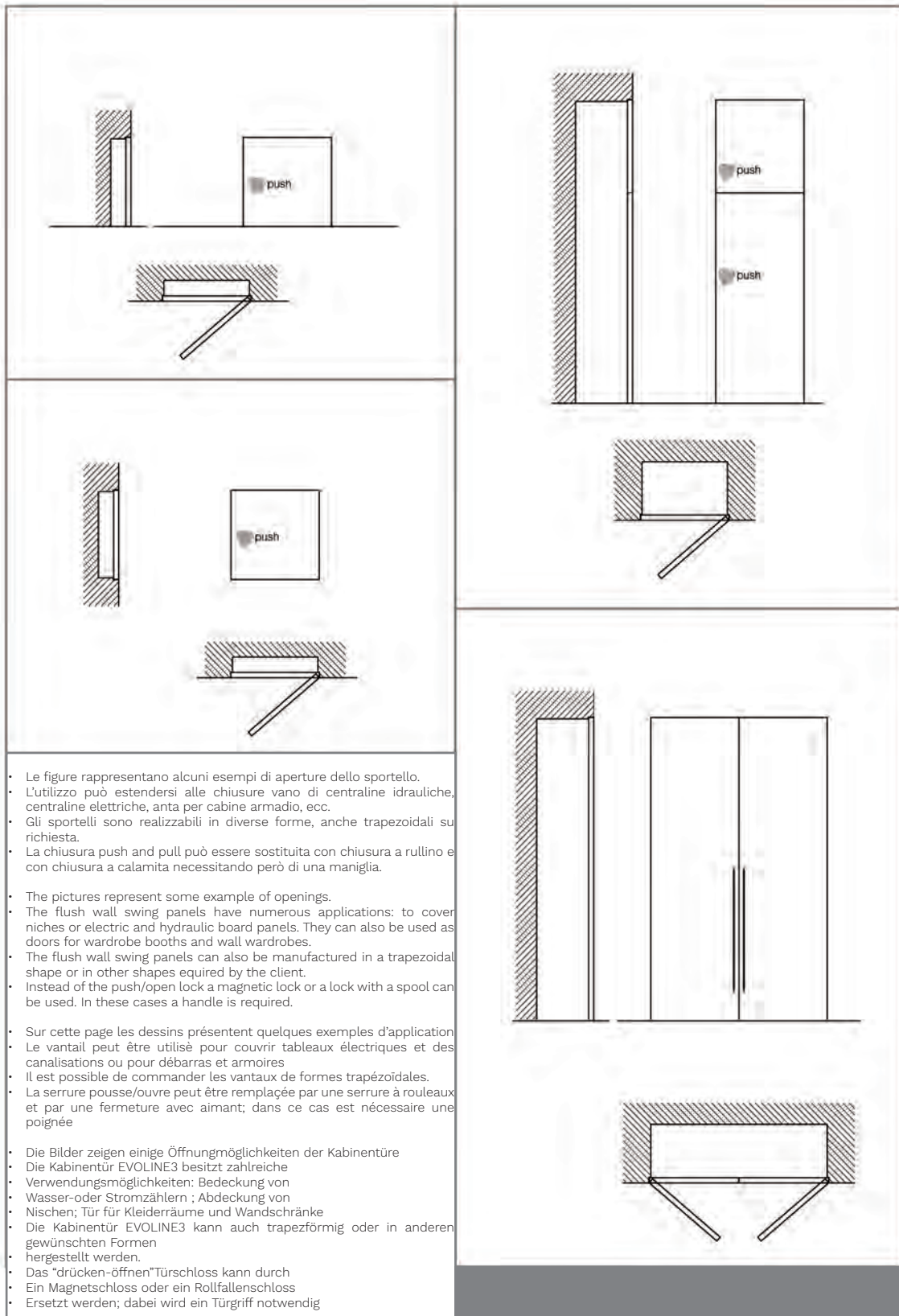

- Le figure rappresentano alcuni esempi di aperture dello sportello.
- L'utilizzo può estendersi alle chiusure vano di centraline idrauliche, centraline elettriche, anta per cabine armadio, ecc.
- Gli sportelli sono realizzabili in diverse forme, anche trapezoidali su richiesta.
- La chiusura push and pull può essere sostituita con chiusura a rullino e con chiusura a calamita necessitando però di una maniglia.

- The pictures represent some example of openings.
- The flush wall swing panels have numerous applications: to cover niches or electric and hydraulic board panels. They can also be used as doors for wardrobe booths and wall wardrobes.
- The flush wall swing panels can also be manufactured in a trapezoidal shape or in other shapes required by the client.
- Instead of the push/open lock a magnetic lock or a lock with a spool can be used. In these cases a handle is required.

- Sur cette page les dessins présentent quelques exemples d'application.
- Le vantail peut être utilisé pour couvrir tableaux électriques et des canalisations ou pour débarras et armoires.
- Il est possible de commander les vantaux de formes trapézoïdales.
- La serrure pousse/ouvre peut être remplacée par une serrure à rouleaux et par une fermeture avec aimant; dans ce cas est nécessaire une poignée.

- Die Bilder zeigen einige Öffnungsmöglichkeiten der Kabinettüre.
- Die Kabinettür EVOLINE3 besitzt zahlreiche Verwendungsmöglichkeiten: Bedeckung von Wasser- oder Stromzählern; Abdeckung von Nischen; Tür für Kleideräume und Wandschränke.
- Die Kabinettür EVOLINE3 kann auch trapezförmig oder in anderen gewünschten Formen hergestellt werden.
- Das "drücken-öffnen"-Türschloss kann durch ein Magnetschloss oder ein Rollfallenschloss ersetzt werden; dabei wird ein Türgriff notwendig.

**SPORTELLO FILOMURO**

WANDBÜNDIGE KABINENTÜRE

VANTAIL AFFLEURANT

FLUSH WALL SWING PANEL

VISTA ASSONOMETRICA / PERSPECTIVE VIEW / PERSPECTIVE / PERSPEKTIVE

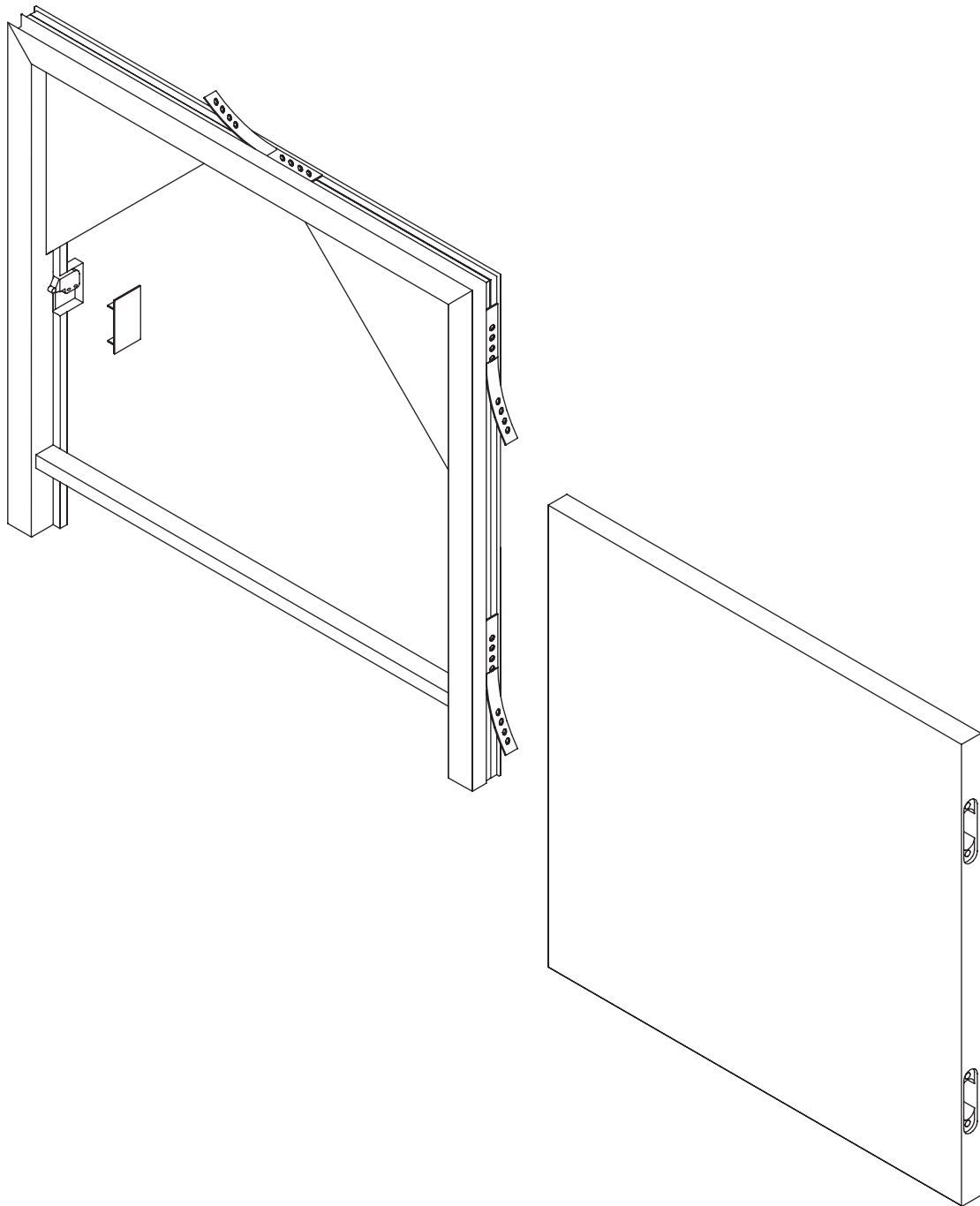

## SPORTELLO FILOMURO > TELAIO SPORTELLO

FLUSH WALL SWING PANEL > FRAME

VANTAIL AFFLEURANT > CHÂSSIS DU VANTAIL

WANDBÜNDIGE KABINENTÜRE > : RAHMEN

LISTINO PREZZI (IVA ESCLUSA) / PRICE LIST (VAT NON INCLUDED) /

LISTE DES PRIX (HORS TVA) / PREISLISTE (MWST NICHT INBEGRIFFEN)

**Telaio porta** spingere/tirare | **muratura/cartongesso**  
**Frame** for push/pull door | **brickwall / plasterboard wall**  
**Châssis** pousser/à tirer | **mur en maçonnerie/mur en placoplâtre**  
**Rahmen zum** Drücken/zum Ziehen | **Mauerwand/Gipskartonwand**

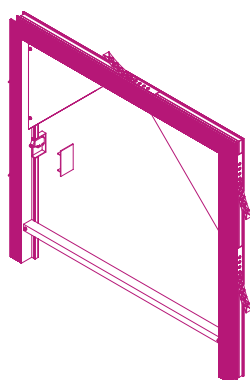

H	da 30 a cm 90	cm 100
da 30 a cm 210	586,00	616,00
cm 220	660,00	693,00
cm 230	660,00	693,00
cm 240	779,00	818,00
cm 250	779,00	818,00
cm 260	779,00	818,00
cm 270	779,00	818,00
cm 280	920,00	966,00
cm 290	920,00	966,00
cm 300	920,00	966,00

SOMMARE IL PREZZO DEL TELAIO AL PREZZO DEL PANNELLO PER AVERE IL COSTO DELLO SPORTELLO  
 THE PRICE OF A COMPLETE SLIDING DOOR IS GIVEN BY THE SUM OF THE RAIL PRICE AND THE PANEL PRICE

Telaio sportello trapezoidale Trapezoidal shaped panel for flush swing panel	Maggiorazione 50% 50% increase
Sportello a bilico Pivoting flush swing panel	Maggiorazione 50% 50% increase
Telaio sportello senza traverso superiore (tutta altezza) Frame for flush swing panel without the upper element (full-height)	No supplemento No additional cost
Telaio porta per anta doppia Panel for a flush swing double panel	Moltiplica prezzo per 2 Please double the price

TELAIO e PANNELLO costituiscono sempre 2 colli, pertanto la consegna può avvenire in tempi diversi  
 FRAME and PANEL are always separately packed and can therefore be delivered at different times



## SPORTELLO FILOMURO > PANNELLO SPORTELLO

FLUSH WALL SWING PANEL > FRAME

VANTAIL AFFLEURANT > CHÂSSIS DU VANTAIL

WANDBÜNDIGE KABINETTÜRE > RAHMEN

LISTINO PREZZI (IVA ESCLUSA) / PRICE LIST (VAT NON INCLUDED) /

LISTE DES PRIX (HORS TVA) / PREISLISTE (MWST NICHT INBEGRIFFEN)

**Pannello porta** | Finitura: **trattamento di fondo**

**Panel** | Finish: **primed**

**Panneau du Vantail** | Finition: **pré-peint**

**Türblatt für Kabinettüre** | Ausführung: **grundiert**



H	L	
	da cm 30 a cm 90	cm 100
da cm 30 a cm 180	542,00	570,00
cm 190*	722,00	750,00
cm 200*	722,00	750,00
cm 210*	722,00	750,00
cm 220*	722,00	750,00
cm 230*	722,00	750,00
cm 240*	820,00	853,00
cm 250*	820,00	853,00
cm 260*	820,00	853,00
cm 270*	820,00	853,00
cm 280*	937,00	974,00
cm 290*	937,00	974,00
cm 300*	937,00	974,00

SOMMARE IL PREZZO DEL PANNELLO AL PREZZO DEL TELAIO PER AVERE IL COSTO DELLA PORTA  
THE PRICE OF A COMPLETE SLIDING DOOR IS GIVEN BY THE SUM OF THE RAIL PRICE AND THE PANEL PRICE

Pannello sportello trapezoidale  
Trapezoidal shaped panel for flush swing panel

Maggiorazione 50%  
50% increase

Sportello a bilico  
Pivoting flush swing panel

Maggiorazione 50%  
50% increase

Pannello sportello per anta doppia  
Panel for a flush swing double panel

Moltiplica prezzo per 2  
Please double the price

TELAIO e PANNELLO costituiscono sempre 2 colli, pertanto la consegna può avvenire in tempi diversi  
FRAME and PANEL are always separately packed and can therefore be delivered at different times

\* Per H > 180 cm il raddrizza anta viene sempre previsto

\* By H > 180 cm inside the panel there is always a steel core

## SPORTELLO FILOMURO > PANNELLO SPORTELLO

FLUSH WALL SWING PANEL > FRAME

VANTAIL AFFLEURANT > CHÂSSIS DU VANTAIL

WANDBÜNDIGE KABINENTÜRE > RAHMEN

LISTINO PREZZI (IVA ESCLUSA) / PRICE LIST (VAT NON INCLUDED) /

LISTE DES PRIX (HORS TVA) / PREISLISTE (MWST NICHT INBEGRIFFEN)

**Pannello porta** | finitura: **laccatura opaca / uniformante sabbato**<sup>1</sup>

**Panel** | finish: **matt lacquering / uniforming treatment sandblasted**<sup>1</sup>

**Panneau du Vantail** | finition: **laqué mat / traitement avec un effet sablé**<sup>1</sup>

**Türblatt für Kabinentüre** | ausführung : **mattlackiert / mit Putz-Effekt** <sup>1</sup>

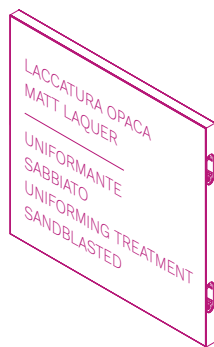

H	L	
	da cm 30 a cm 90	cm 100
da 30 a cm 180	640,00	837,00
cm 190*	820,00	1.017,00
cm 200*	820,00	1.017,00
cm 210*	820,00	1.017,00
cm 220*	820,00	1.017,00
cm 230*	820,00	1.017,00
cm 240*	1.162,00	1.212,00
cm 250*	1.162,00	1.212,00
cm 260*	1.162,00	1.212,00
cm 270*	1.162,00	1.212,00
cm 280*	1.260,00	1.314,00
cm 290*	1.260,00	1.314,00
cm 300*	1.260,00	1.314,00

SOMMARE IL PREZZO DEL PANNELLO AL PREZZO DEL TELAIO PER AVERE IL COSTO DELLA PORTA  
THE PRICE OF A COMPLETE SLIDING DOOR IS GIVEN BY THE SUM OF THE RAIL PRICE AND THE PANEL PRICE

Pannello sportello trapezoidale  
Trapezoidal shaped panel for flush swing panel

Maggiorazione 50%  
50% increase

Sportello a bilico  
Pivoting flush swing panel

Maggiorazione 50%  
50% increase

Pannello sportello per anta doppia  
Panel for a flush swing double panel

Moltiplica prezzo per 2  
Please double the price

N.B. I pannelli laccati vengono forniti con i componenti (serratura, cerniere) installati  
Remark: Lacquered panels are always supplied with the components (lock, hinges and seal) already installed

TELAIO e PANNELLO costituiscono sempre 2 colli, pertanto la consegna può avvenire in tempi diversi  
FRAME and PANEL are always separately packed and can therefore be delivered at different times

<sup>1</sup> Applicativo idoneo per uniformare il pannello alla parete quando gli intonaci sono al civile.

\* Per H > 180 cm il raddrizza anta viene sempre previsto.

<sup>1</sup> Two-coat plaster work. This plaster is the ideal solution when the doorpanel shall be uniform with the wall and when the walls are made of a two-coat plaster work.

\* By H > 180 cm inside the panel there is always a steel core.

**SPORTELLO FILOMURO > MANIGLIA RICAVATA**

FLUSH WALL SWING PANEL > BUILT-IN HANDLE

VANTAIL AFFLEURANT > POIGNÉE ENCASTRÉE

WANDBÜNDIGE KABINETTÜR > EINGELASSENER TÜRGRIFF

POSIZIONE A  
POSITION A

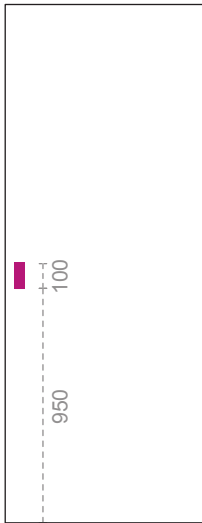

POSIZIONE B  
POSITION B

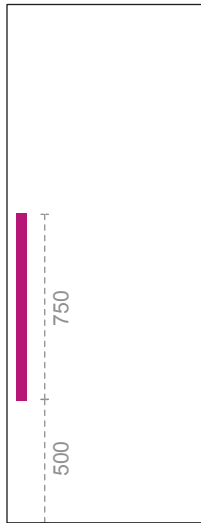

POSIZIONE C  
POSITION C

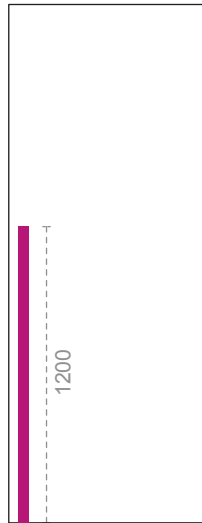

POSIZIONE D  
POSITION D

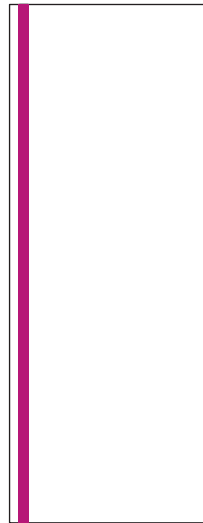

SEZIONI MANIGLIA  
SECTION OF BUILT-IN HANDLE



POSIZIONE E  
POSITION E

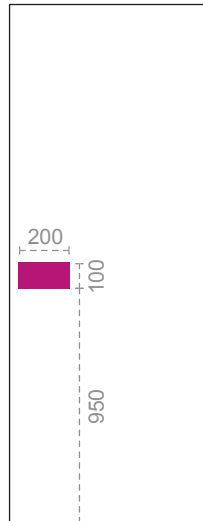

SEZIONI MANIGLIA  
SECTION OF BUILT-IN HANDLE

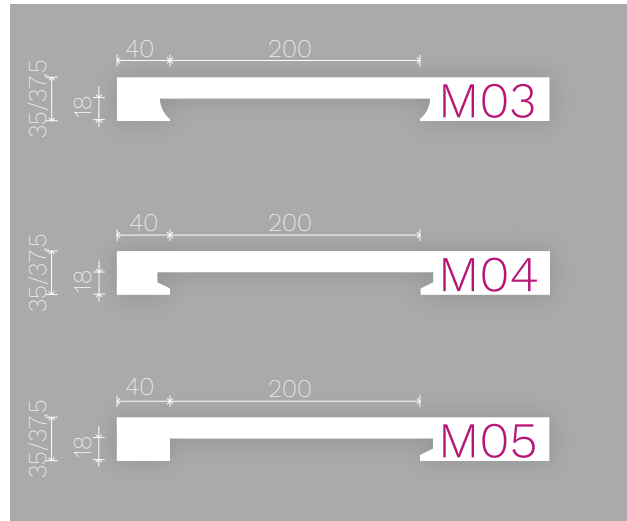

POSIZIONE F  
POSITION F

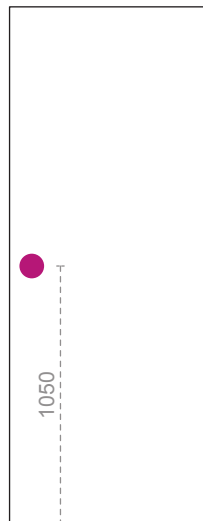

SEZIONI MANIGLIA  
SECTION OF BUILT-IN HANDLE





**SPORTELLO FILOMURO**  
**FLUSH WALL SWING PANEL**  
**VANTAIL AFFLEURANT**  
**WANDBÜNDIGE KABINENTÜRE**

LISTINO PREZZI (IVA ESCLUSA) / PRICE LIST (VAT NON INCLUDED) /  
 LISTE DES PRIX (HORS TVA) / PREISLISTE (MWST NICHT INBEGRIFFEN)

**OPTIONALS**

ART. ITEM.	DESCRIZIONE DESCRIPTION		PREZZO PRICE
	Sportello 4 lati Flush swing panel on 4 sides		Maggiorazione 5% 5% increase
S04	Serratura a rullino Door lock with spool	[vedi T049-C] [look at T049-C]	No supplemento No additional cost
S06	Serratura a spillo Pin lock	[vedi T101-C] [look at T101-C]	€ 108,00
B NO HA	Maniglia ricavata nel pannello su un lato (da abbinare con serratura a rullino) Built-in door handle on a side of the panel, to be matched to the lock with spool	[vedi pag. 85] [look at pag. 85]	€ 200,00 cadauna € 200,00 each handle
	Serratura - Maniglia Bonaiti a filo pannello Lock-Handle of Bonaiti, flush to the door panel		€ 460,00
	Pannello insonorizzato (sughero all'interno) Sound-proof panel (cork inside)	[vedi T198-B] [look at T198-B]	€ 280,00 (pannello h 210) (panel h 210) € 390,00 (pannello h 210 - 300) (panel h 210 - 300)
	Pannello in multistrati pieno Sound-proof panel	[vedi T198-A] [look at T198-A]	€ 700,00 (pannello h 210) (panel h 210) € 810,00 (pannello h 210 - 300) (panel h 210 - 300)
Per altri tipi di esigenze si invita ad inoltrare la richiesta For further requests please contact the company			

TEMPI DI CONSEGNA > COSTO DELLA SPEDIZIONE (ITALIA) / MANUFACTURING TIMES> FREIGHT COSTS  
 (ONLY FOR ITALY VALID) / TEMPS DE FABRICATION > FRAIS DE LIVRAISON (VALABLES SEULEMENT POUR L'ITALIE) /  
 HERSTELLUNGSZEIT> FRACHTKOSTEN (NUR IN ITALIEN GÜLTIG)

TELAIO SPORTELLO FRAME for flush swing panel	6 gg lavorativi + tempo di spedizione 6 working days + delivery time
ANTA SPORTELLO trattamento di fondo PANEL Priming treatment	25 gg lavorativi + tempo di spedizione 25 working days + delivery time
ANTA SPORTELLO laccato opaco / uniformante sabbiato PANEL Matt lacquering / uniforming treatment sandblasted	35 gg lavorativi + tempo di spedizione 35 working days + delivery time

**SPORTELLO FILOMURO**  
 FLUSH WALL SWING PANEL  
 VANTAIL AFFLEURANT  
 WANDBÜNDIGE KABINENTÜRE

COME DEFINIRE LE SPECIFICHE / HOW TO DEFINE THE SPECIFICATIONS /  
 COMME ON DEFINI LES SPECIFICATIONS / WIE DIE EIGENSCHAFTEN BESTIMMT WERDEN

Telaio o anta H 210	€ 21,00 a collo
Telaio o anta H 210 - 300	€ 29,00 a collo
Supplemento per la spedizione nelle isole	€ 6,00 a collo
Per spedizioni fuori dall'Italia richiedere preventivo For deliveries out of Italy please ask for a quotation	
N.B. TELAIO E PANNELLO COSTITUISCONO SEMPRE 2 COLLI REMARKS: THE DOOR FRAME AND THE DOOR PANEL ARE ALWAYS PACKED IN 2 PACKING UNITS	

COME DEFINIRE LE SPECIFICHE / HOW TO DEFINE THE SPECIFICATIONS /  
 COMME ON DEFINI LES SPECIFICATIONS / WIE DIE EIGENSCHAFTEN BESTIMMT WERDEN

- **riferimento cantiere:** indicare un riferimento per ogni porta
- **dimensione netta di passaggio:** L x H
- **sensi di apertura:** destra o sinistra
- **tipologia di muro:** muratura o cartongesso
- **tipo di finitura pannello:** trattamento di fondo, laccatura opaca RAL, uniformante sabbiato
- **eventuali optional**

- **Reference on the yard:** please indicate a reference for each door
- **Net dimension of the passage :** L x H
- **Opening directions:** right or left
- **Kind of wall :** brickwall or plasterboard wall
- **Kind of finish of the door panel:** primed, RAL matt lacquered, sandblasted
- **possible optional**

- **référence du chantier :** indiquer une référence pour chaque porte
- **Dimensions nets du passage :** L x H
- **Vers d'ouverture:** droite ou gauche
- **Typologie du mur:** maçonnerie ou placoplâtre
- **Typologie de finition du panneau:** pré-peint, laqué matte RAL, avec un effet sablé
- **accessoires possibles**

- **Bezug bei Baustelle:** für jede Türe einen Bezug nennen
- **Durchgangsmassen :** L x H
- **Öffnungsrichtungen:** Rechts oder Links
- **Mauertyp:** Gipskarton oder Mauerwand
- **Oberfläche des Türblattes:** grundiert, in RAL-Mattlack, mit Putz-Effekt
- **Mögliches Zubehör**

TELAIO SPINGERE CARTONGESSO  
FRAME TO PUSH ON PLASTERBOARD WALL

TELAIO TIRARE MURATURA  
FRAME TO PULL ON A BRICKWALL

TELAIO TIRARE CARTONGESSO  
FRAME TO PULL ON A PLASTERBOARD WALL

TELAIO PORTA 102  
FRAME FOR DOOR 102

PANNELLO MULTISTRATI  
DOOR PANEL IN MULTILAYER

PANNELLO IN SUGHERO INSONORIZZATO  
DOOR PANEL SOUNDPROOF

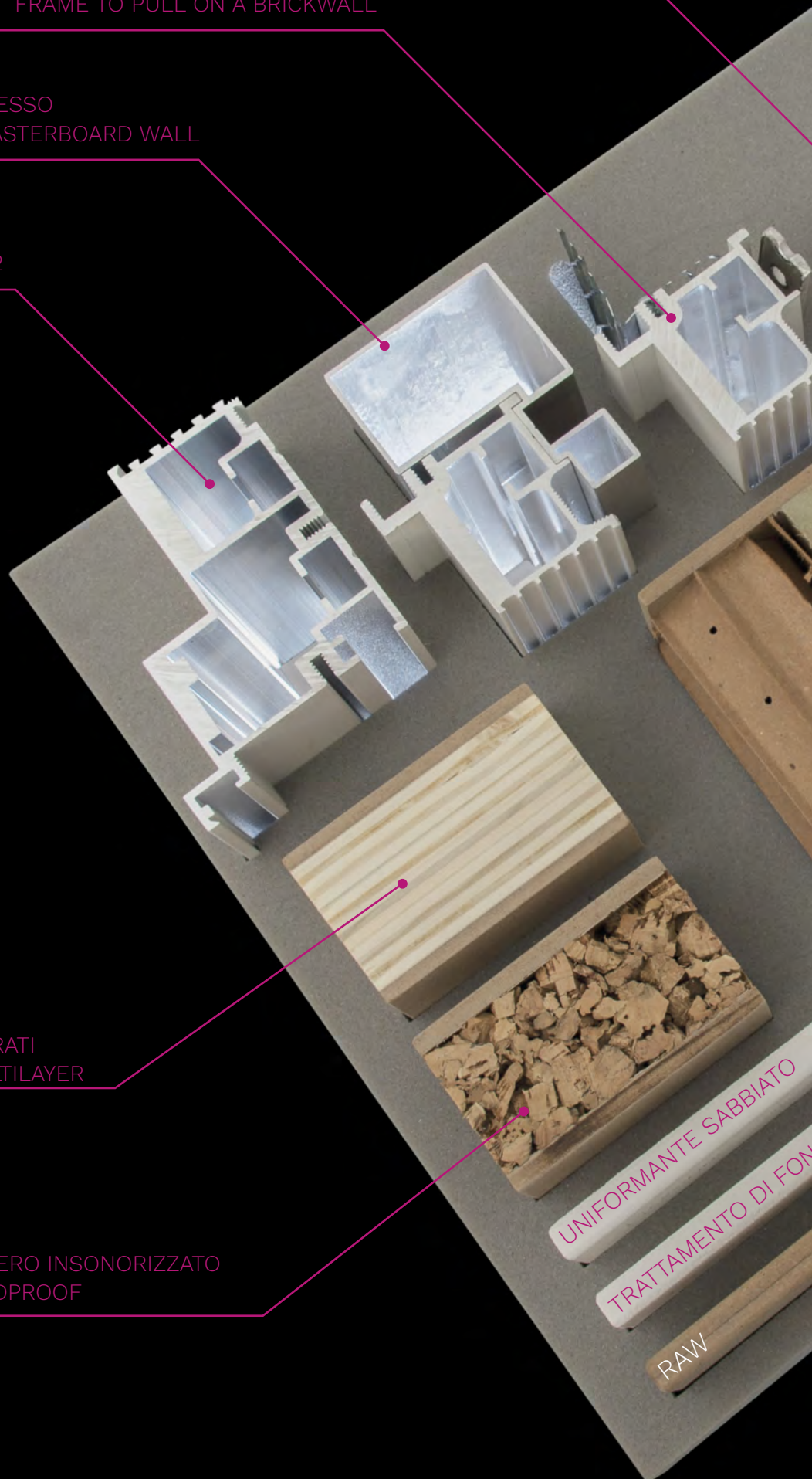

TELAIO SPINGERE MURATURA  
DOOR FRAME TO PUSH ON A BRICKWALL

PANNELLO TAMBURATO SPORTELLO  
HONEYCOMB FLUSH SWING PANEL

PANNELLO TAMBURATO PORTA  
HONEYCOMB FLUSH SWING DOOR PANEL

RAL 9001

RAL 9003

RAL 9010

RAL 1013

WHITE

RAL 9016

PANNELLO TAMBURATO 102  
HONEYCOMB FLUSH SWING DOOR PANEL 102

# DETTAGLI DI LAVORAZIONE

DETAILS OF PROCESSING  
DETAILS DE FABRICATION  
DETAILS ZUM FERTIGUNGSPROZESS

## T009

Predisposizione maniglia incasso tonda  
Adjustment for built-in handle TONDA

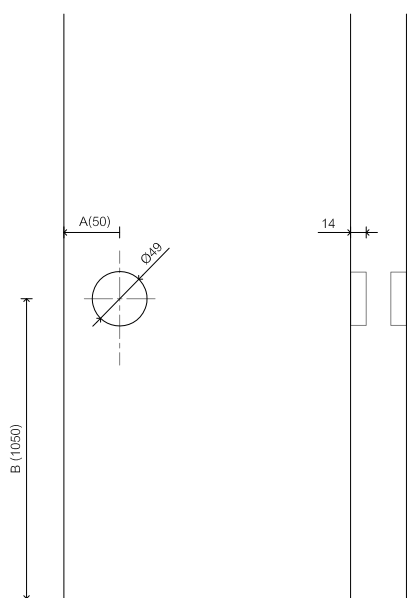

A

B

Nodo centrale per doppia anta scorrevole contrapposta  
Central part of a double sliding door where one panel is opposite to the other

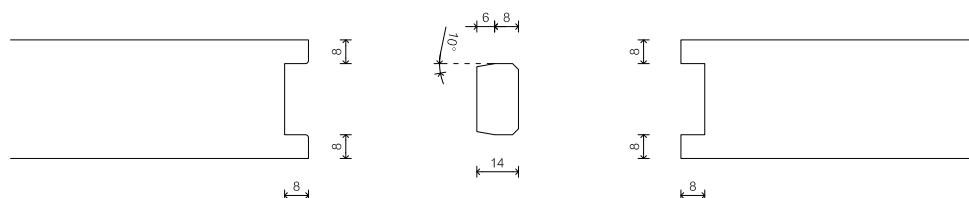
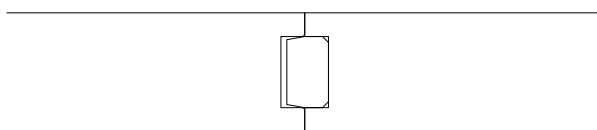

C

# DETTAGLI DI LAVORAZIONE

DETAILS OF PROCESSING  
DETAILS DE FABRICATION  
DETAILS ZUM FERTIGUNGSPROZESS

## T010

Foro su pannello – Incontro – Serratura a gancio – BONAITI 061  
Hole on the door panel - Plate for hook lock of BONAITI 061

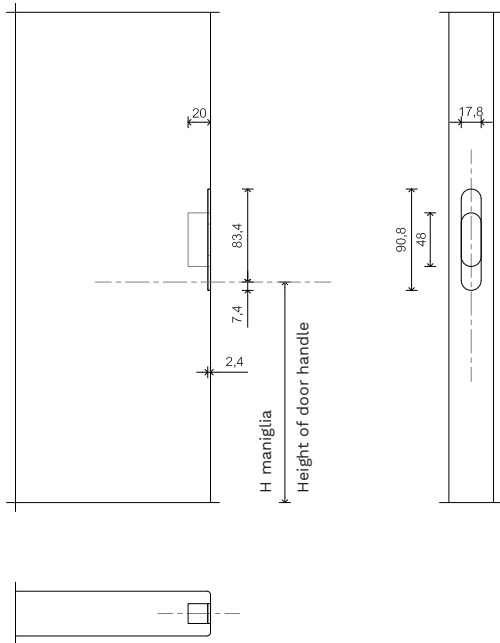

A

Foro su pannello – Serratura a gancio – BONAITI 061 – E50 – F16  
Hole on the door panel - hook lock - BONAITI 061 – E50 – F16

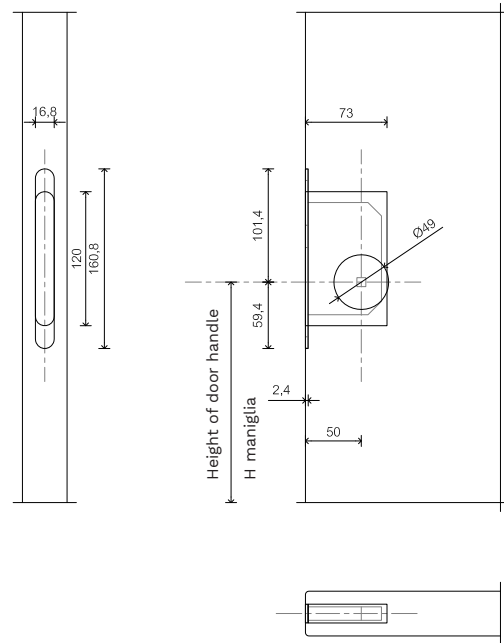

B

Predisposizione pozzetto di trascinamento per doppia anta scorrevole contrapposta  
Adjustment for hole on the panelborder of a double swing door with opposite panel

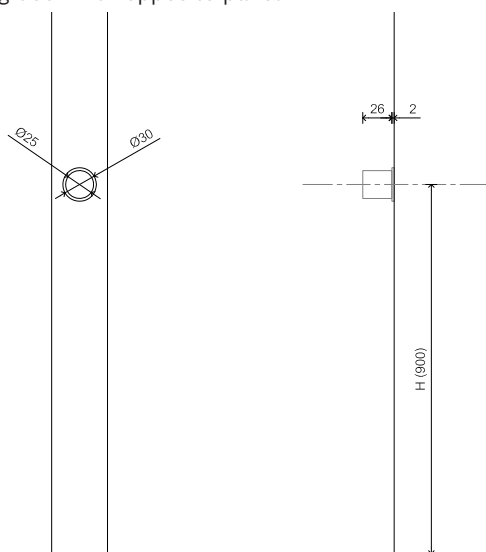

C

Predisposizione pozzetto di trascinamento  
Adjustment for hole on the panelborder

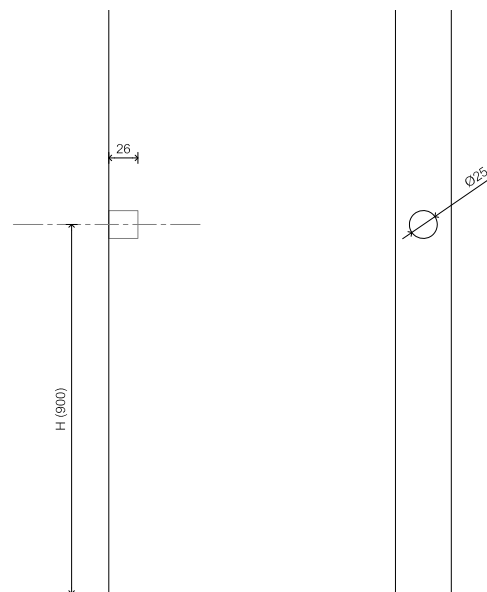

D

# DETTAGLI DI LAVORAZIONE

DETAILS OF PROCESSING  
DETAILS DE FABRICATION  
DETAILS ZUM FERTIGUNGSPROZESS

## T032

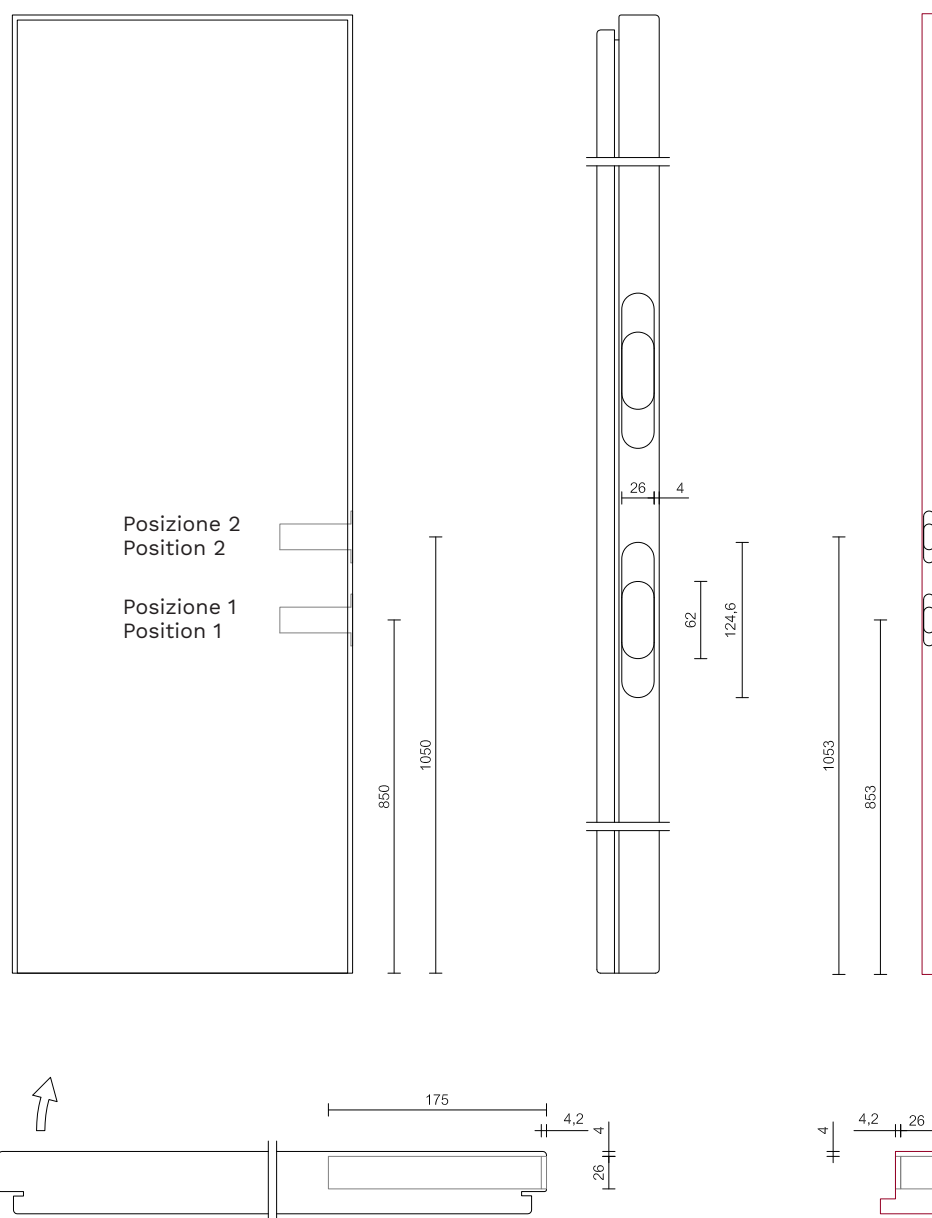

# DETTAGLI DI LAVORAZIONE

DETAILS OF PROCESSING  
DETAILS DE FABRICATION  
DETAILS ZUM FERTIGUNGSPROZESS

## T033

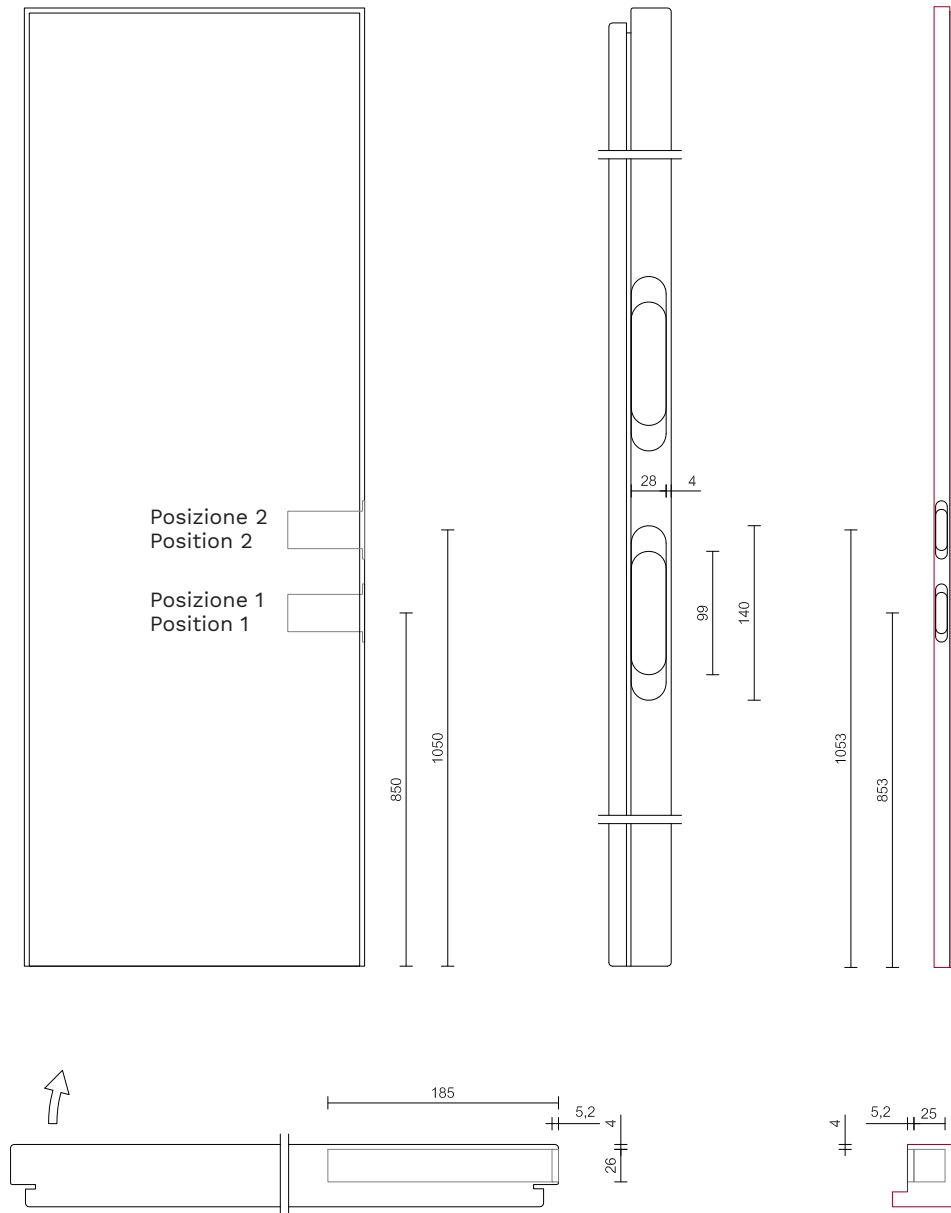



# DETTAGLI DI LAVORAZIONE

DETAILS OF PROCESSING

DETAILS DE FABRICATION

DETAILS ZUM FERTIGUNGSPROZESS

## T034

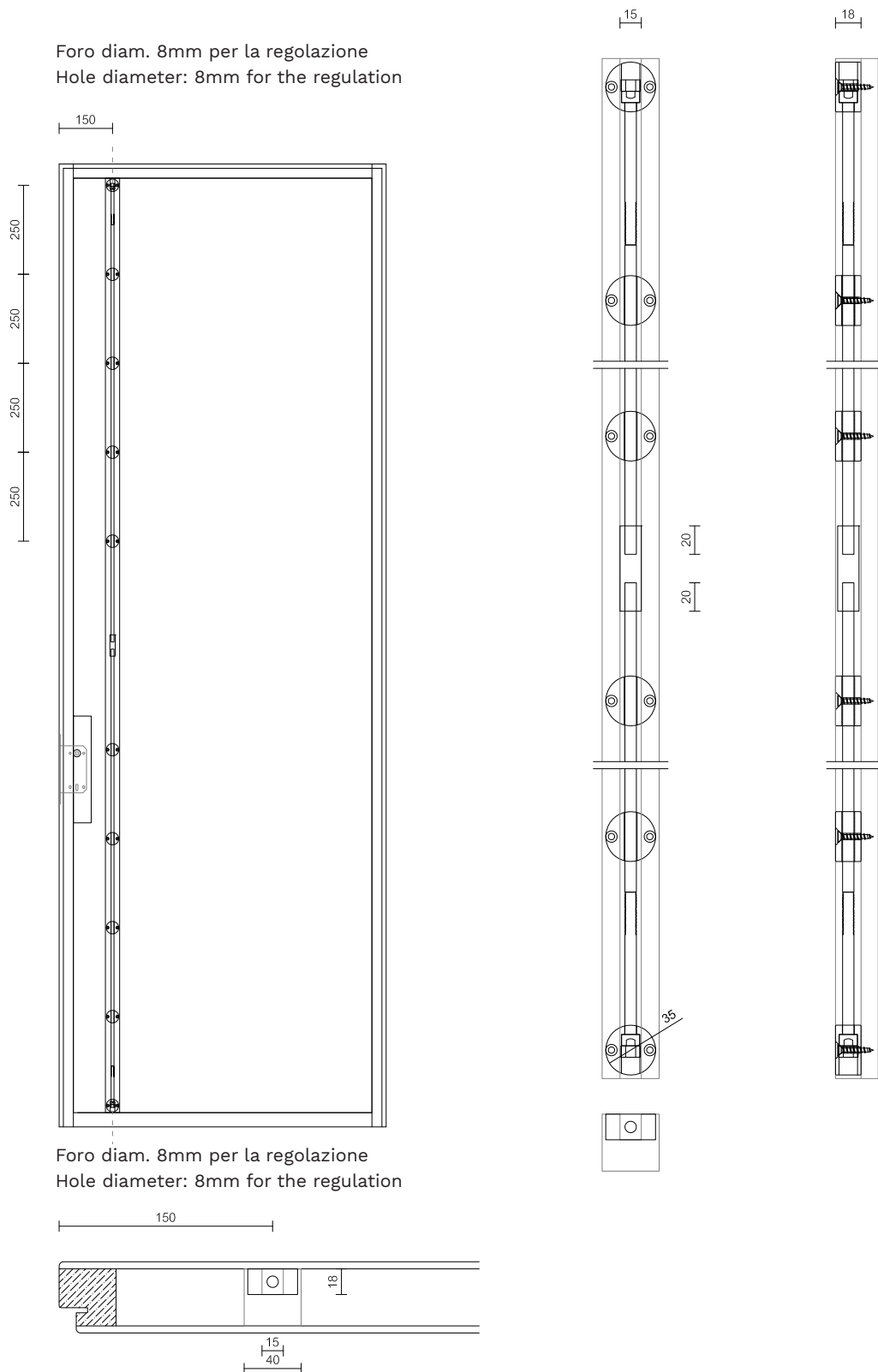

# DETTAGLI DI LAVORAZIONE

DETAILS OF PROCESSING  
DETAILS DE FABRICATION  
DETAILS ZUM FERTIGUNGSPROZESS

## T036

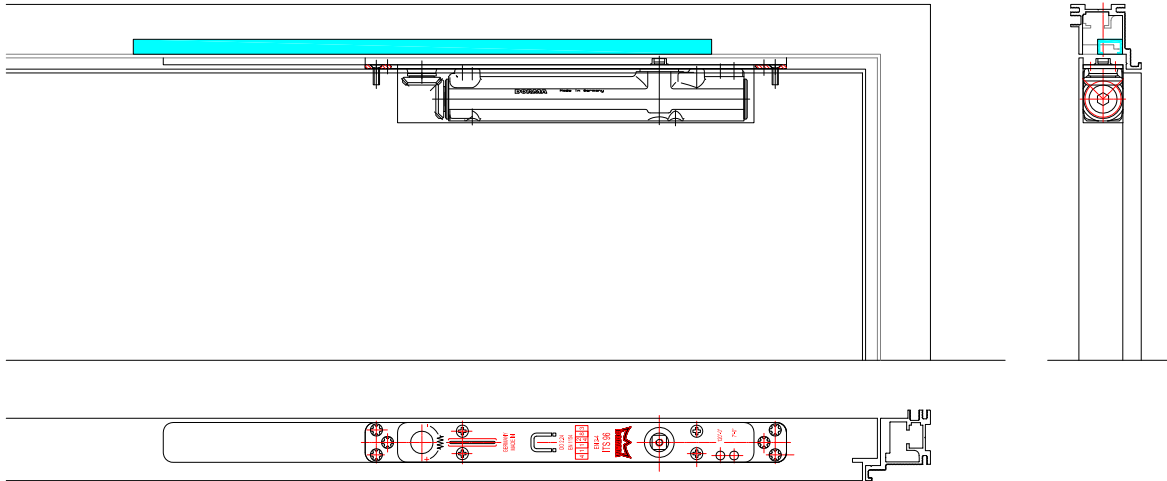

Foro su traverso alluminio  
Hole on the aluminium upper frame

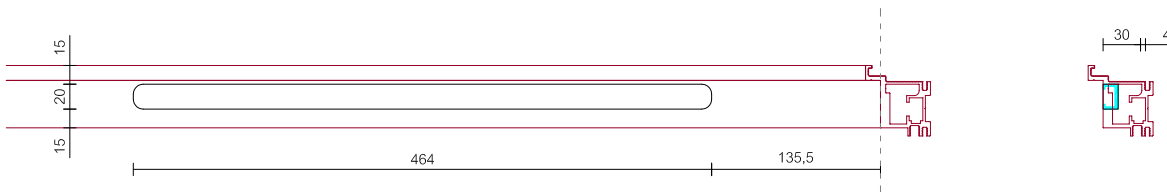

Foro pannello  
Hole on the door panel

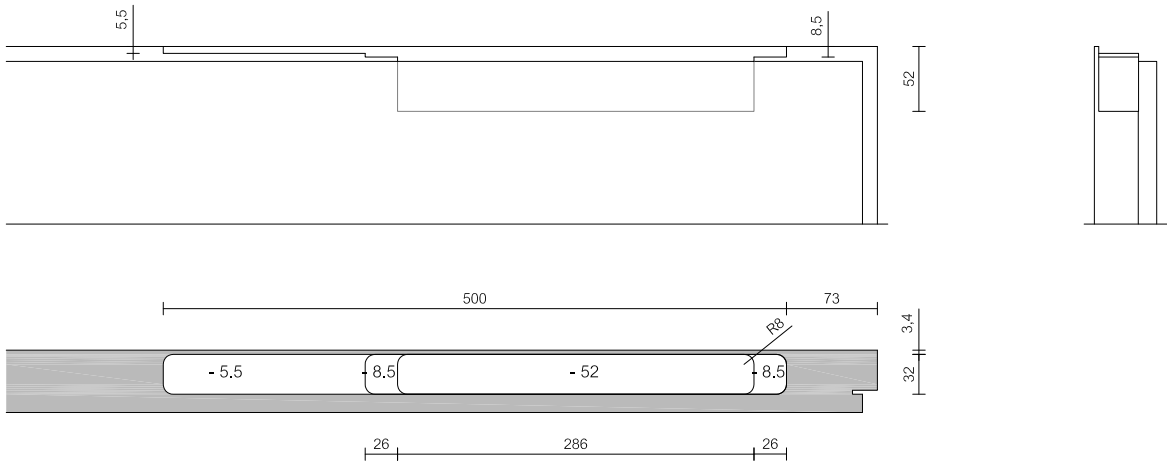

# DETTAGLI DI LAVORAZIONE

DETAILS OF PROCESSING  
 DETAILS DE FABRICATION  
 DETAILS ZUM FERTIGUNGSPROZESS

## T047

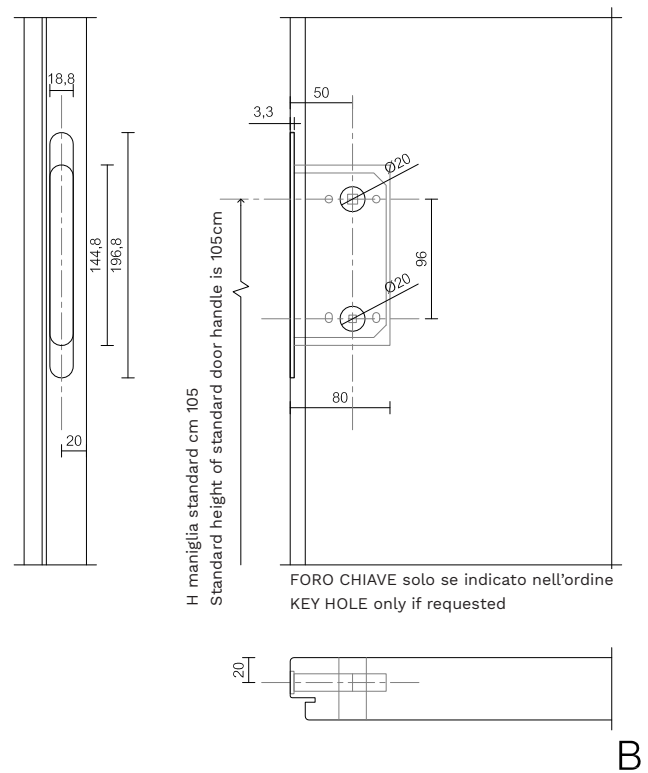
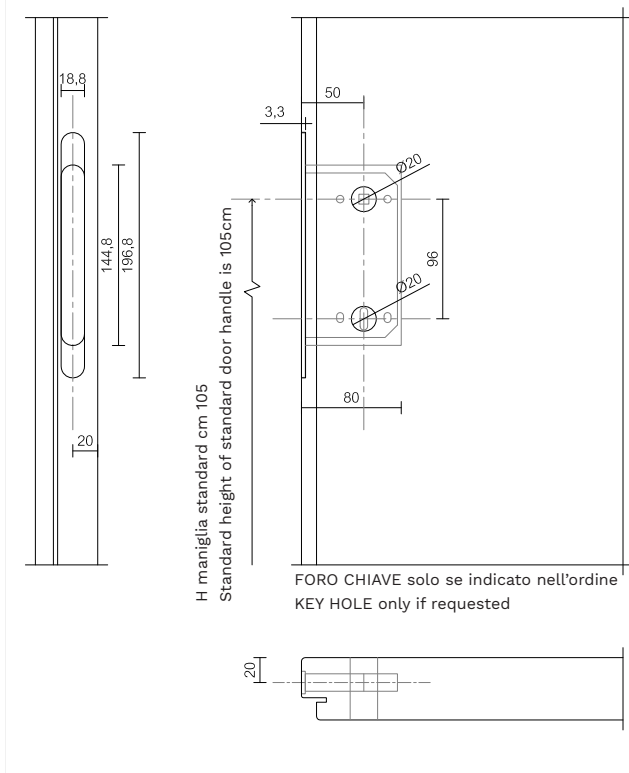

FORO SU PANNELLO – serratura standard – AGB SERRATURA  
 MAGNETICA Yale Polaris E50  
 HOLE ON THE DOOR PANEL – standard lock- magnetic yale  
 lock of AGB, item Polaris E50

FORO CHIAVE – Foro chiave passante  
 KEY HOLE- key hole on both sides of the door panel

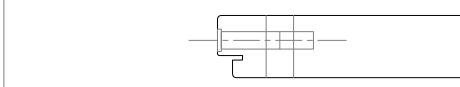
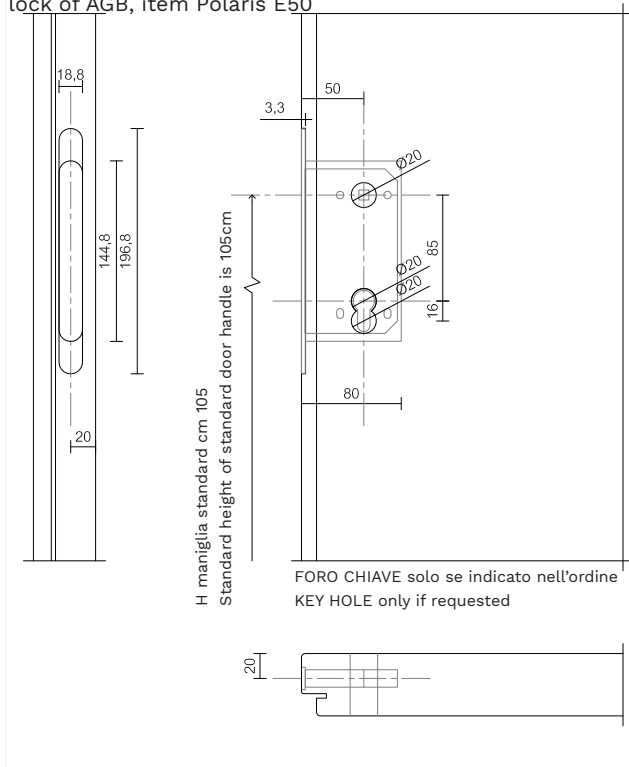

Foro chiave - solo un lato indicato nell'ordine  
 Key hole on both sides of the door panel

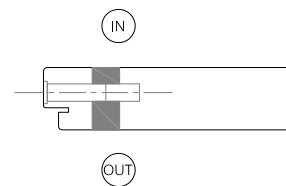

# DETTAGLI DI LAVORAZIONE

DETAILS OF PROCESSING  
DETAILS DE FABRICATION  
DETAILS ZUM FERTIGUNGSPROZESS

## T048

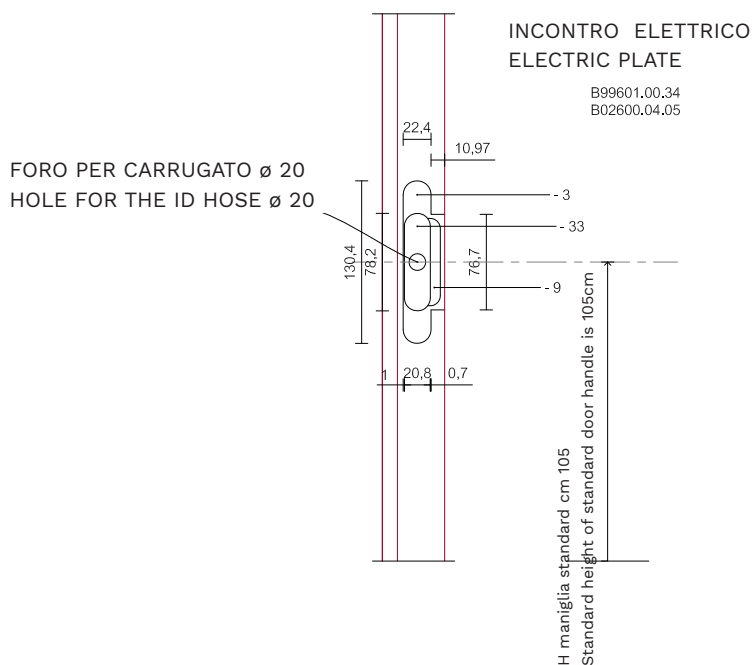

A

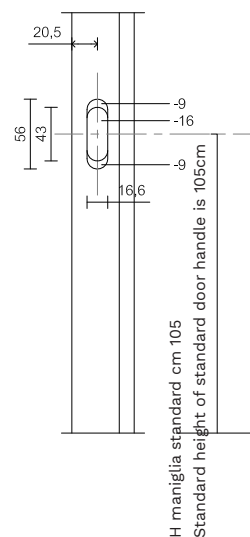

B

Foro su telaio – incontro magnetico AGB  
Hole on door frame- magnetic lock plate AGB

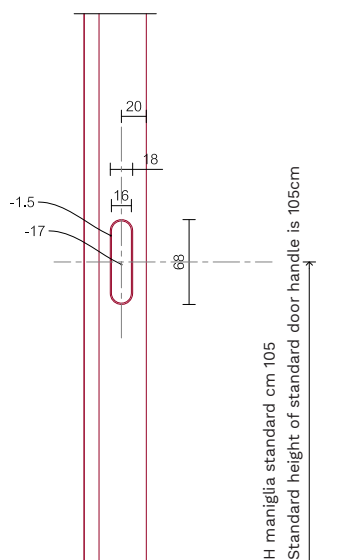

C

D

# DETTAGLI DI LAVORAZIONE

DETAILS OF PROCESSING  
DETAILS DE FABRICATION  
DETAILS ZUM FERTIGUNGSPROZESS

## T049

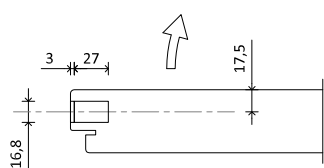
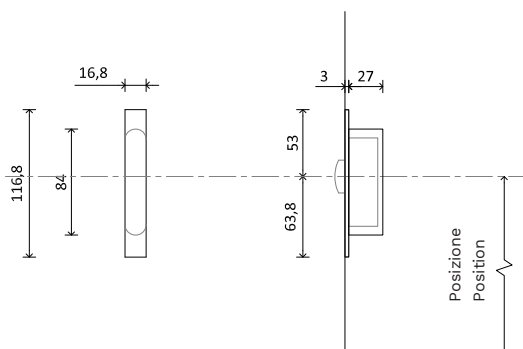

A

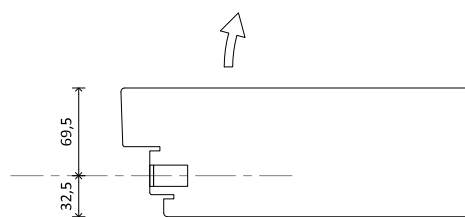
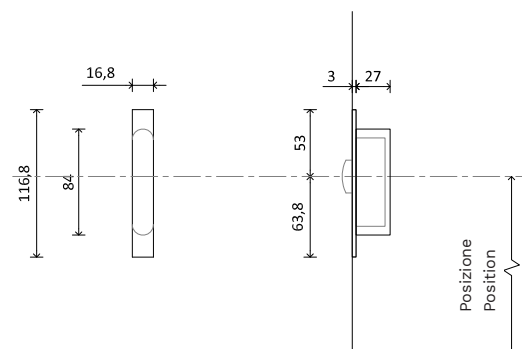

B

FORO SU PANNELLO mm 37.5 - Serratura rullino CISA  
HOLE ON DOOR PANEL mm 37.5 - spool lock CISA

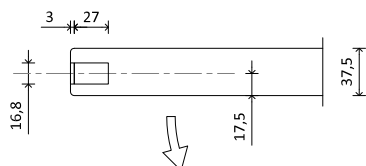
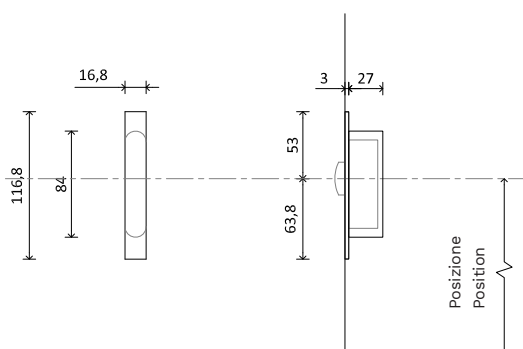

C

# DETTAGLI DI LAVORAZIONE

DETAILS OF PROCESSING  
DETAILS DE FABRICATION  
DETAILS ZUM FERTIGUNGSPROZESS

## T050

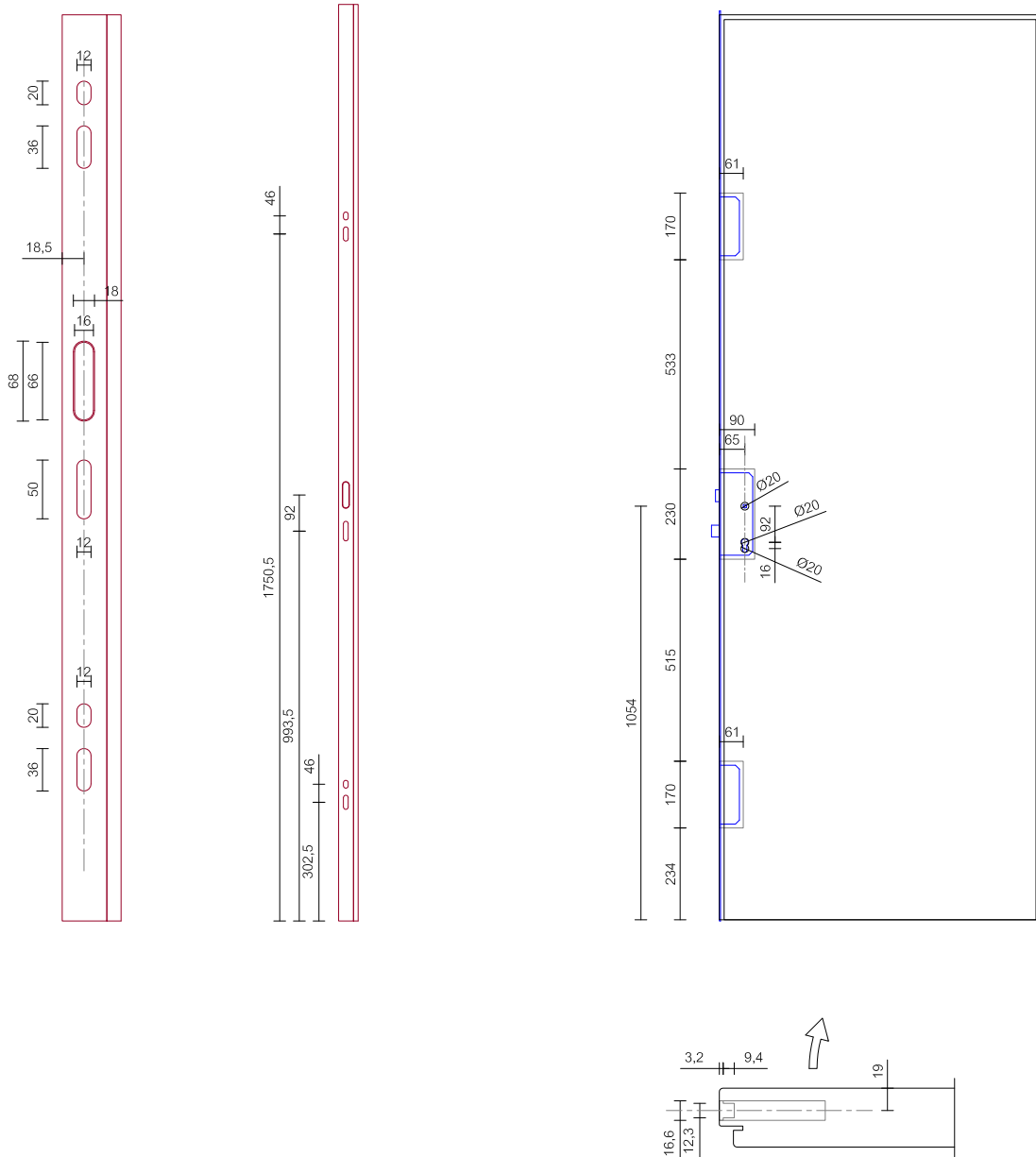

# DETTAGLI DI LAVORAZIONE

DETAILS OF PROCESSING  
DETAILS DE FABRICATION  
DETAILS ZUM FERTIGUNGSPROZESS

## T053

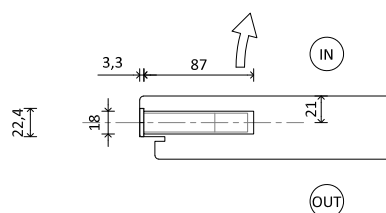
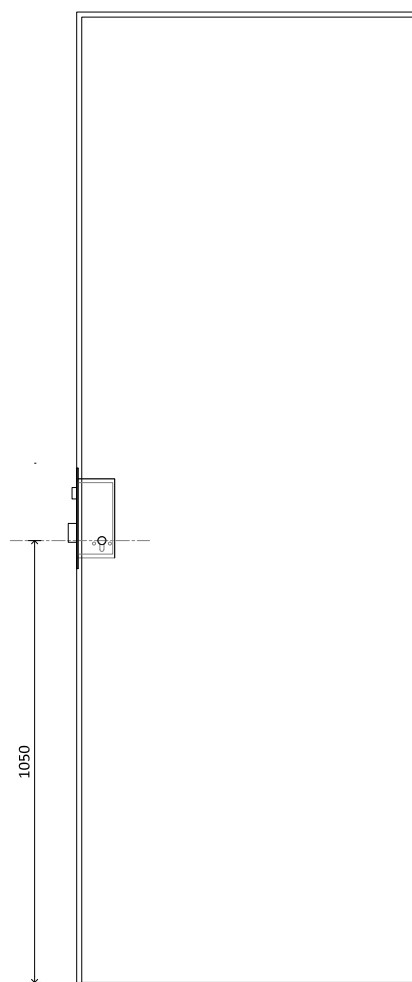
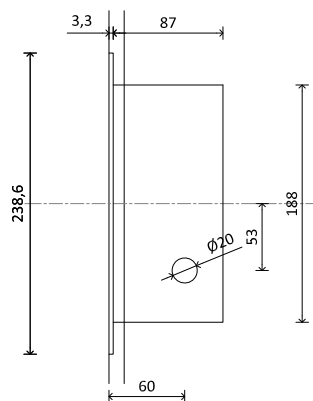
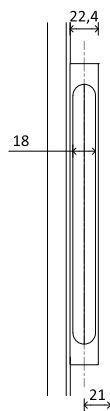
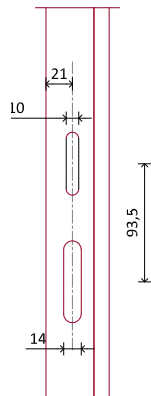

# DETTAGLI DI LAVORAZIONE

DETAILS OF PROCESSING  
DETAILS DE FABRICATION  
DETAILS ZUM FERTIGUNGSPROZESS

## T057

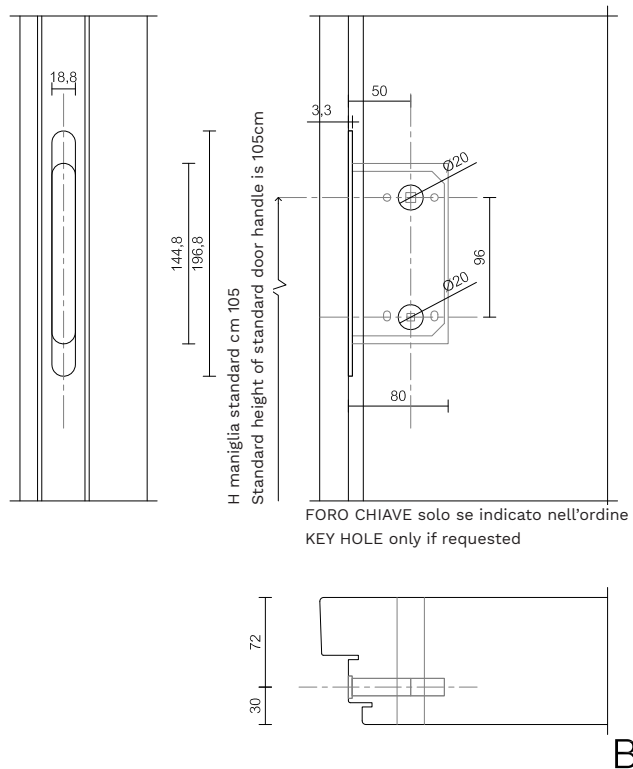
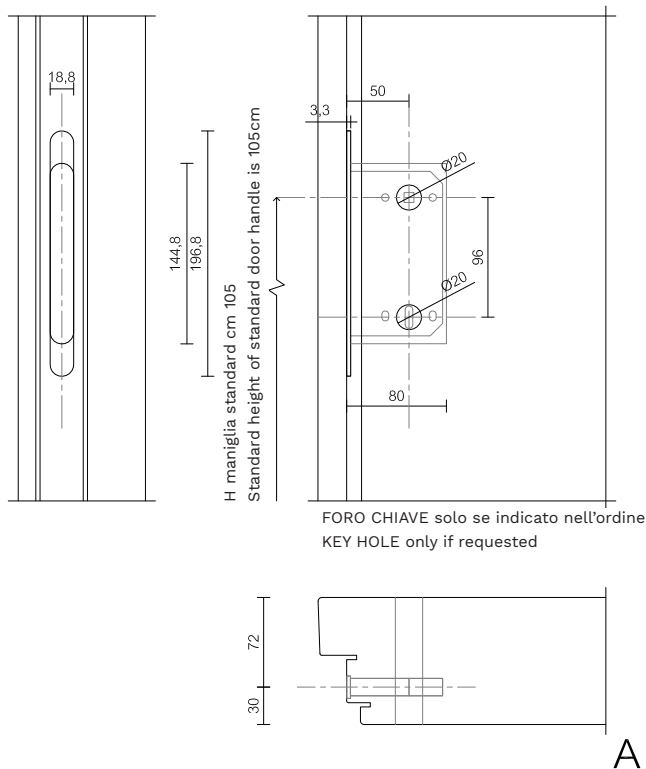

FORO SU PANNELLO – serratura standard – AGB SERRATURA  
MAGNETICA Yale Polaris E50  
HOLE ON THE DOOR PANEL – standard lock- magnetic yale  
lock of AGB, item Polaris E50

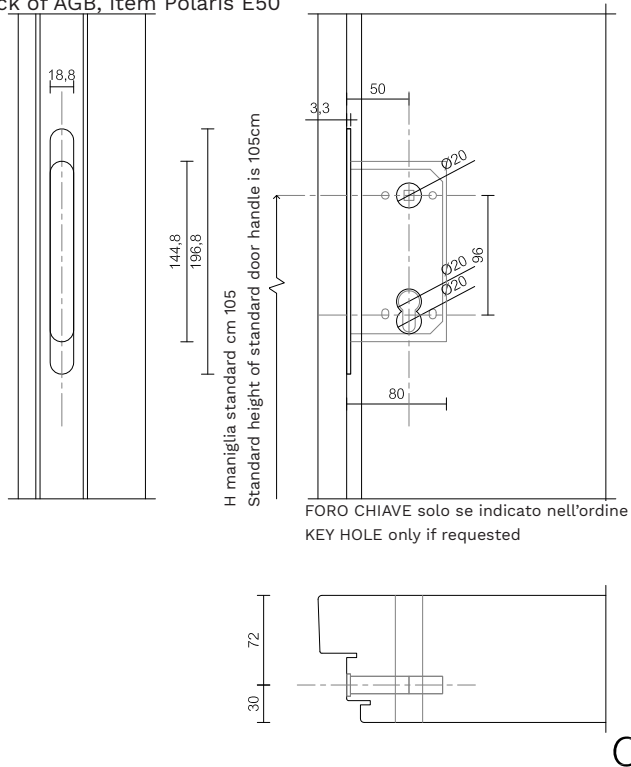

FORO CHIAVE – Foro chiave passante  
KEY HOLE- key hole on both sides of the door panel

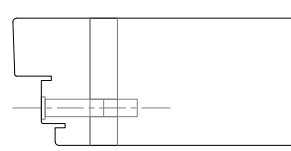

Foro chiave - solo un lato indicato nell'ordine  
Key hole on both sides of the door panel

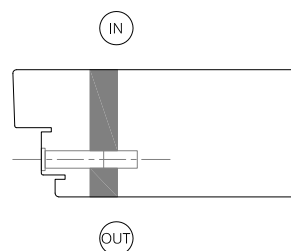

D



# DETTAGLI DI LAVORAZIONE

DETAILS OF PROCESSING  
 DETAILS DE FABRICATION  
 DETAILS ZUM FERTIGUNGSPROZESS

## T058

FORO SU PANNELLO - Lama sotto porta termoacustica MAICO su pannello Porta 102 mm 102 Battuta inferiore per soglia  
 HOLE ON DOOR PANEL thermoacoustic blade of MAICO on doorpanel of door 102  
 The Joke on the lower side for the threshold is 102mm

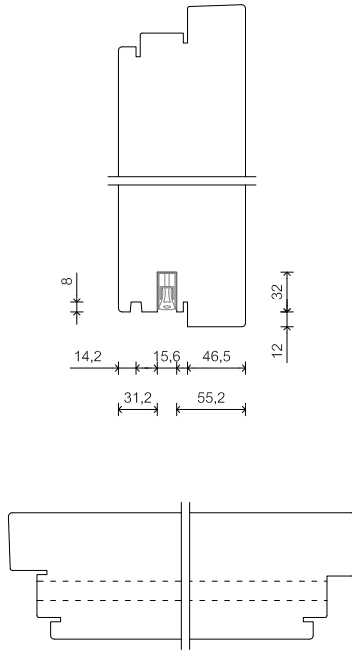

A

FORO SU PANNELLO . lama sotto porta termoacustica MAICO su pannello Porta 102 mm 102  
 HOLE ON DOOR PANEL thermoacoustic blade of MAICO on door-panel of door 102 102mm

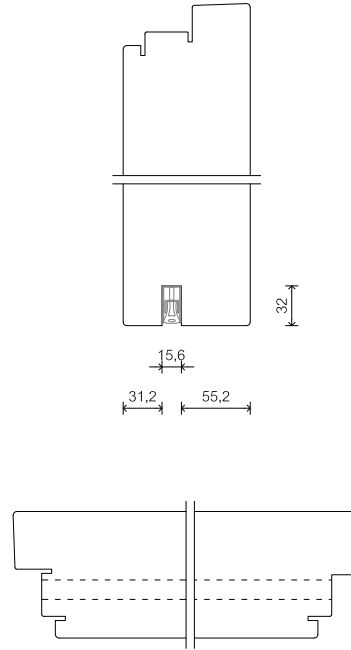

B

FORO SU PANNELLO - lama sotto porta termoacustica MAICO su pannello Porta 102 mm 102  
 HOLE ON DOOR PANEL thermoacoustic blade of MAICO on doorpanel of door 102 102mm

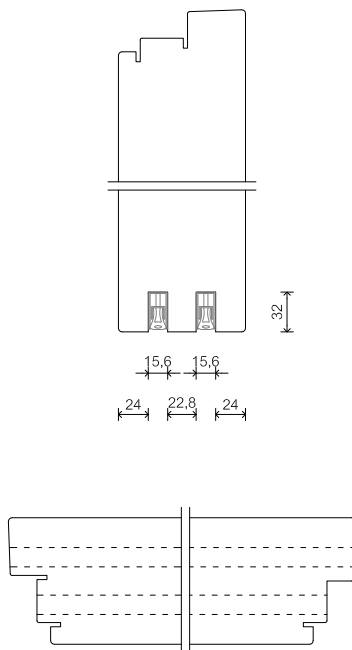

C

FORO SU PANNELLO . lama sotto porta termoacustica MAICO su pannello standard mm 50  
 HOLE ON DOOR PANEL thermoacoustic blade of MAICO on standard doorpanel 50mm

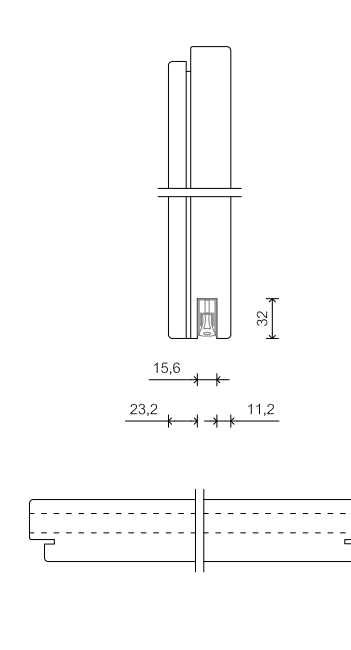

D

# DETTAGLI DI LAVORAZIONE

DETAILS OF PROCESSING  
DETAILS DE FABRICATION  
DETAILS ZUM FERTIGUNGSPROZESS

## T073

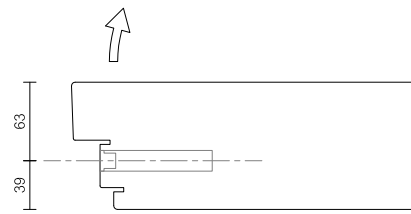
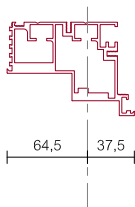
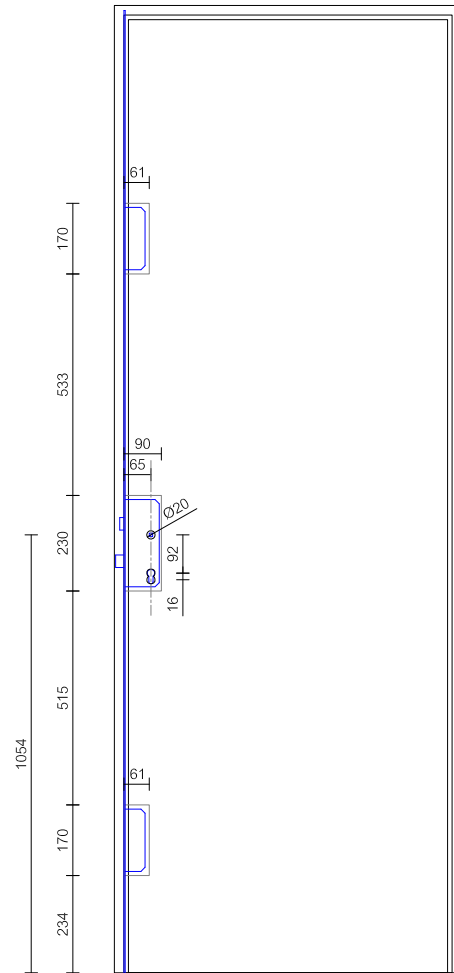
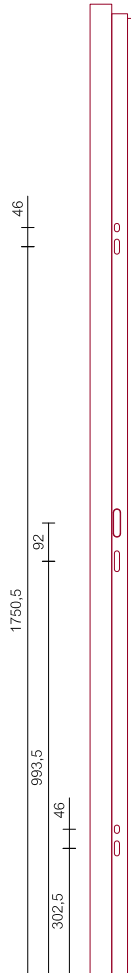
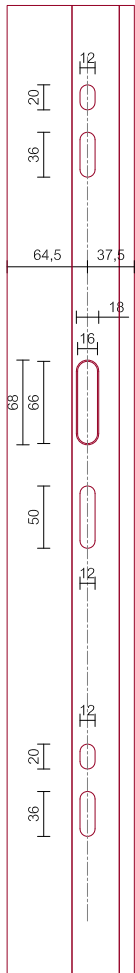

# DETTAGLI DI LAVORAZIONE

DETAILS OF PROCESSING  
 DETAILS DE FABRICATION  
 DETAILS ZUM FERTIGUNGSPROZESS

## T101

Foro su pannello mm 50 – serratura spillo E50  
 Hole on door panel 50mm – spool lock E50

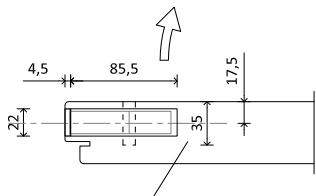
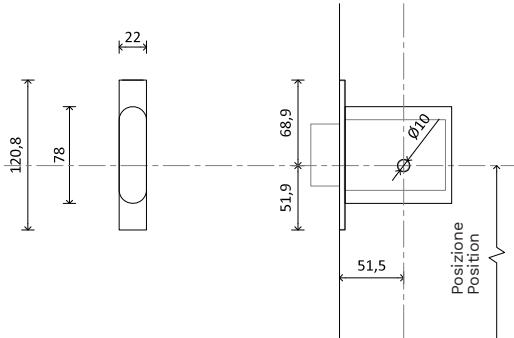

Prof. Foro chiave quando non passante / Depth of the keyhole, when only on one side

Foro su pannello mm 102- serratura a spillo E50  
 Hole on door panel 102mm – pin lock E50

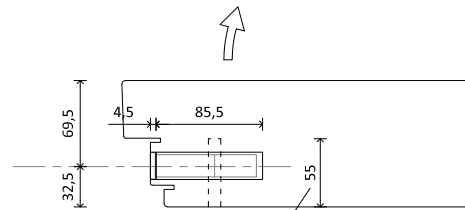
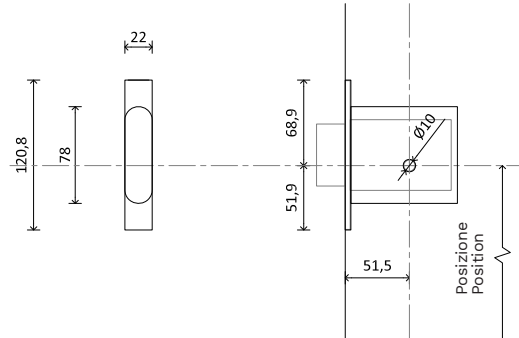

Prof. Foro chiave quando non passante / Depth of the keyhole, when only on one side

A

B

FORO SU PANNELLO mm 37.5/35 – SERRATURA SPILLO E50  
 HOLE ON DOOR PANEL mm 37.5/35-PIN LOCK E50

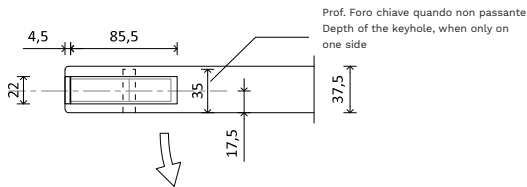
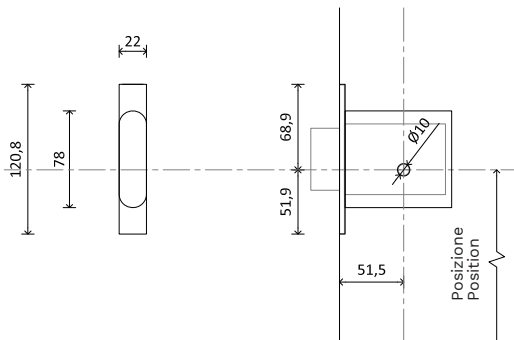

Prof. Foro chiave quando non passante  
 Depth of the keyhole, when only on one side

C

# DETTAGLI DI LAVORAZIONE

DETAILS OF PROCESSING  
DETAILS DE FABRICATION  
DETAILS ZUM FERTIGUNGSPROZESS

## T104

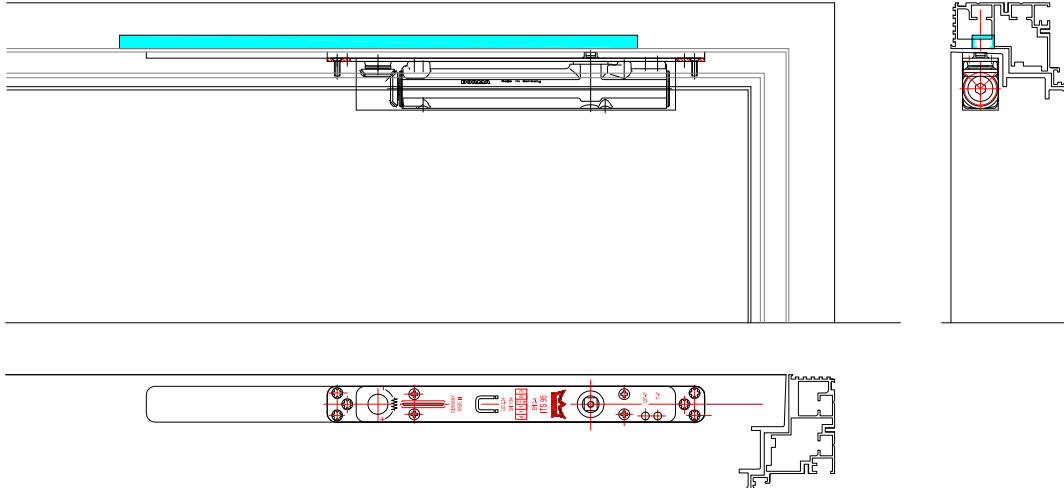

Foro su traverso alluminio  
Hole on aluminium frame

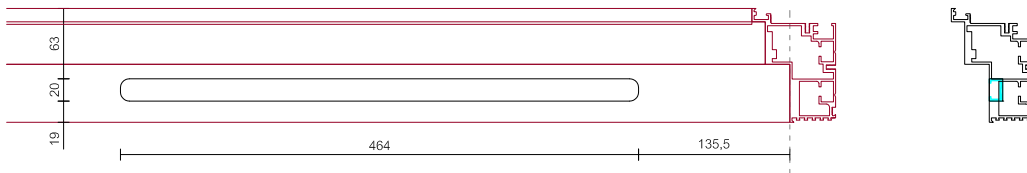

Foro pannello  
Hole on the panel

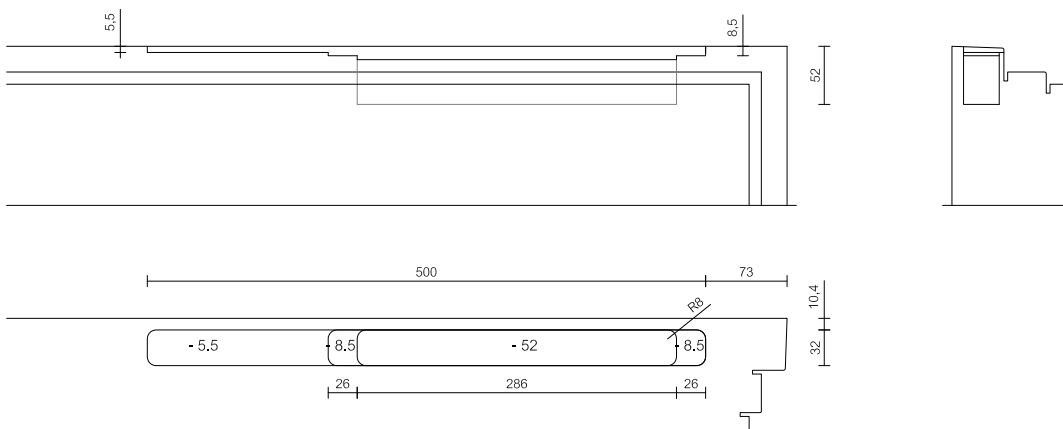

# DETTAGLI DI LAVORAZIONE

DETAILS OF PROCESSING  
DETAILS DE FABRICATION  
DETAILS ZUM FERTIGUNGSPROZESS

## T148

PANNELLO 102 – multistrati pieno  
DOOR PANEL 102- in full multilayer

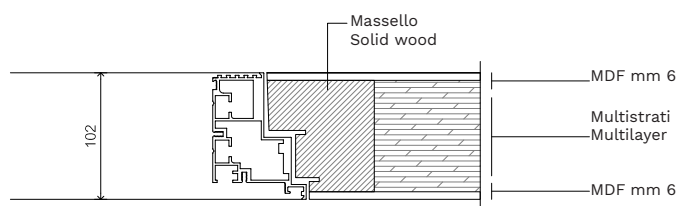

A

PANNELLO 102- insonorizzato con sughero  
DOOR PANEL 102- soundproof with cork

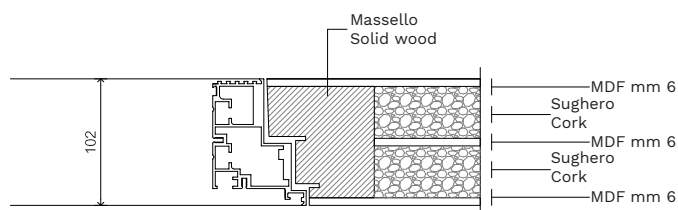

B

# DETTAGLI DI LAVORAZIONE

DETAILS OF PROCESSING  
DETAILS DE FABRICATION  
DETAILS ZUM FERTIGUNGSPROZESS

## T198

PANNELLO: stratigrafia  
DOOR PANEL: stratigraphy

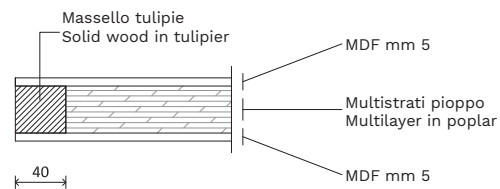

PANNELLO: stratigrafia  
DOOR PANEL: stratigraphy

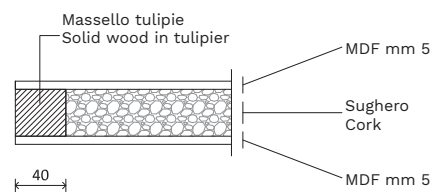

# SOLUZIONI

## MANIGLIE PORTE SCORREVOLI A VETRO

SOLUTIONS HANDLES FOR SLIDING GLASS DOORS

SOLUTIONS POIGNEES POUR PORTES COULISSANTES EN VERRE

LÖSUNGEN TÜRGRIFFE FÜR GLAS-SCHIEBETÜREN

POSIZIONE A  
POSITION A

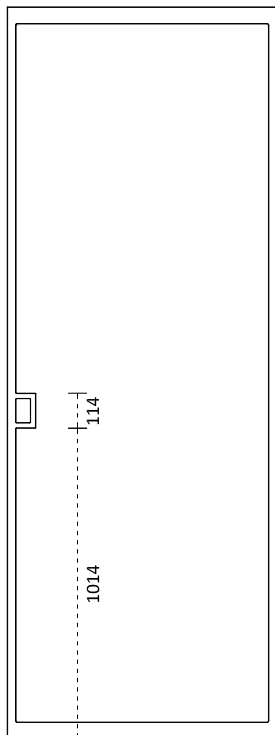

POSIZIONE B  
POSITION B

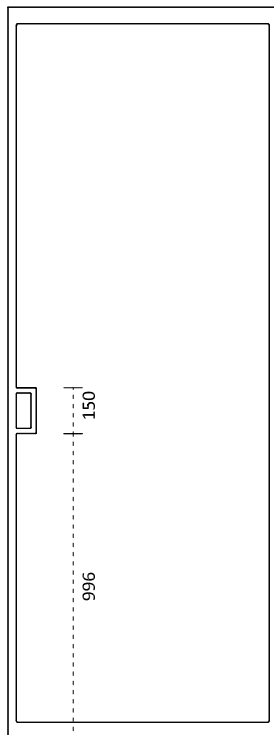

POSIZIONE C  
POSITION C

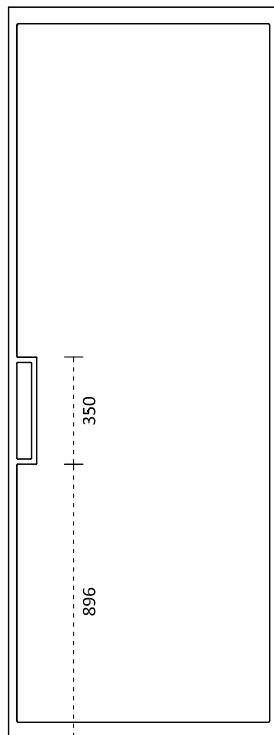

POSIZIONE D  
POSITION D

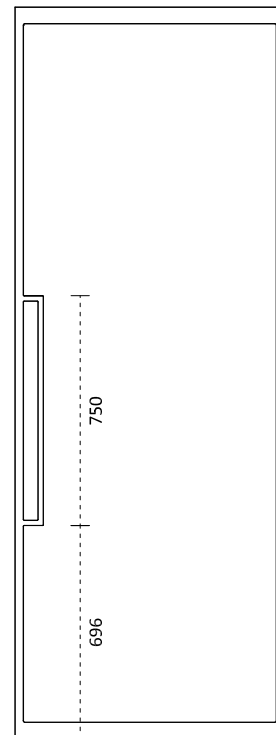

POSIZIONE E  
POSITION E

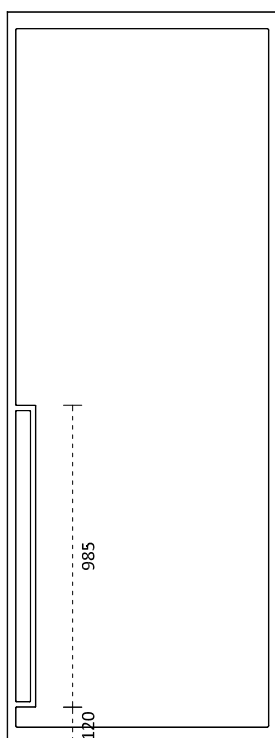

POSIZIONE F  
POSITION F

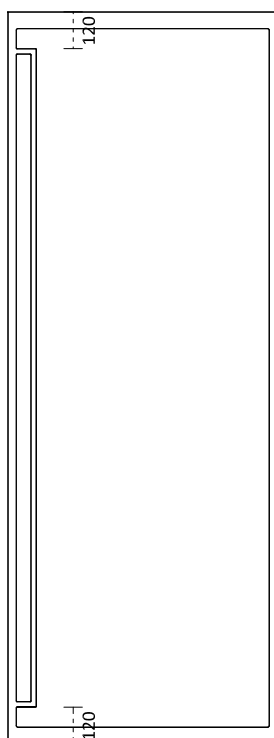

POSIZIONE G  
POSITION G

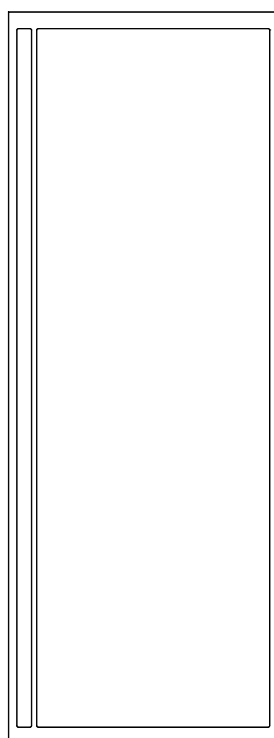

POSIZIONE H  
POSITION H

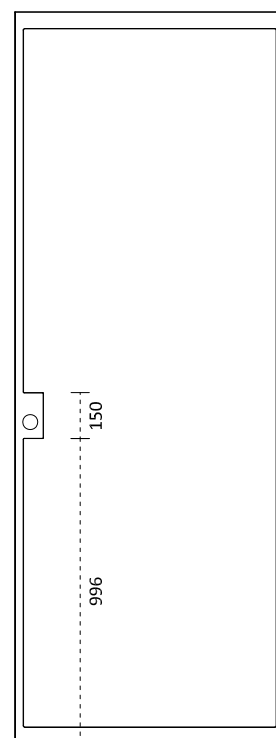

# DETTAGLI ANTA IN VETRO

DETAILS GLASS DOOR PANEL  
DETAILS PANNEAU EN VERRE  
DETAILS TÜRBLATT AUS GLAS

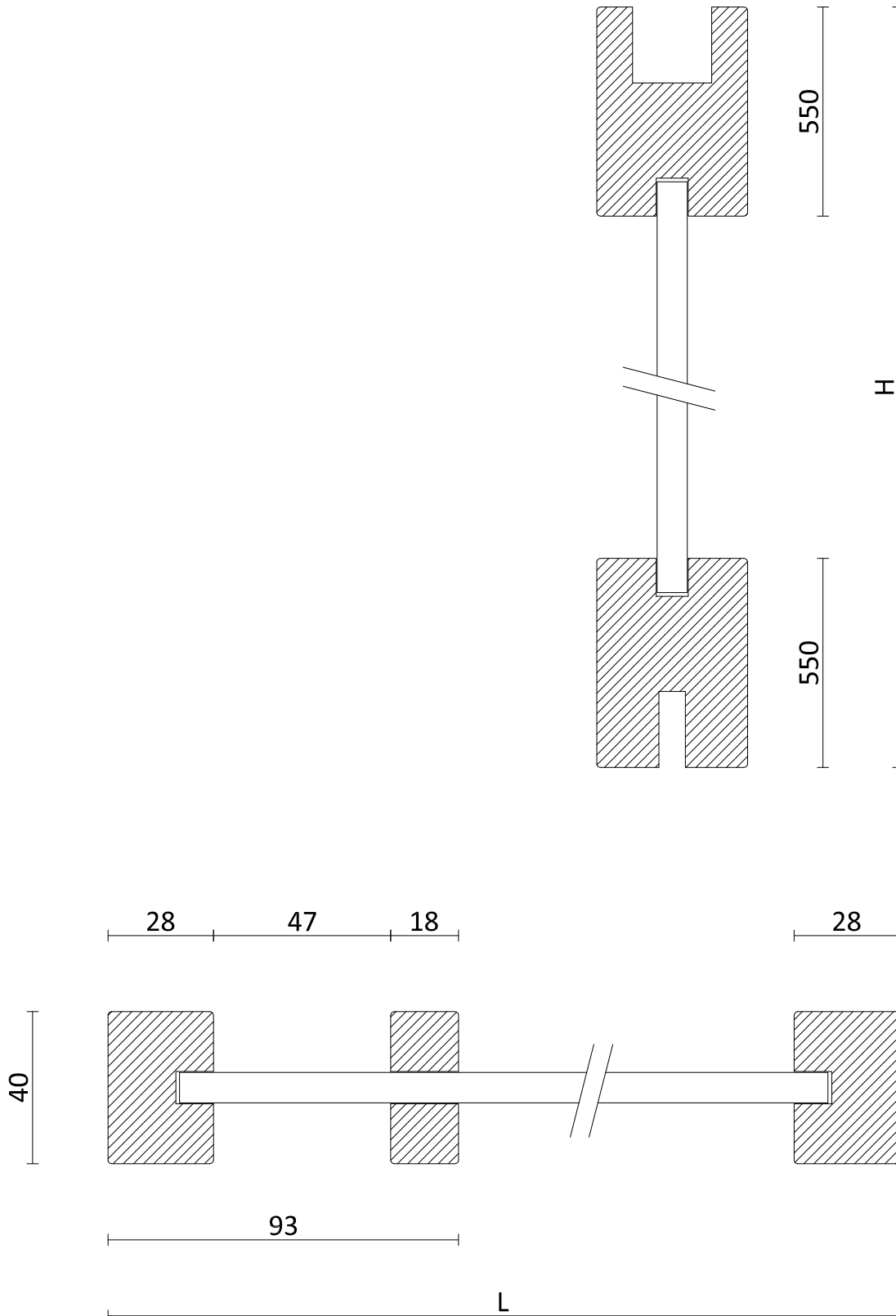



# CONDIZIONI DI VENDITA SALES TERMS AND CONDITIONS CONDITIONS GÉNÉRALES DE VENTE ALLGEMEINE GESCHÄFTSBEDINGUNGEN

## ACCETTAZIONE ORDINI

Tutti gli ordini trasmessi si intendono accettati esclusivamente mediante l'invio al Committente della relativa conferma d'ordine da parte della Falegnameria Serrana; gli stessi vengono accettati alle condizioni generali di vendita in essere. La possibilità di effettuare aggiunte agli ordini già trasmessi è condizionata allo stato di evasione dell'ordine e deve essere di volta in volta verificata contattando il nostro Ufficio Commerciale. Qualsiasi modifica o risoluzione consensuale deve essere fatta per iscritto.

## PREZZI

Il presente listino prezzi sostituisce integralmente ogni listino precedente; i prezzi riportati sono espressi in Euro, IVA esclusa e si intendono al pubblico.

## MODIFICHE AI PRODOTTI E VALIDITA' DELLE INFORMAZIONI

La Falegnameria Serrana segue una politica di costante miglioramento del prodotto, pertanto disegni, dimensioni, finiture sono indicati riservandosi il diritto di modifica senza preavviso. I dati e le immagini riportati nel listino

prezzi ed in tutta la documentazione tecnica sono quindi da ritenersi validi salvo errori di stampa ed eventuali modifiche da parte della Falegnameria Serrana.

## TERMINI DI CONSEGNA

La Falegnameria Serrana si impegna a consegnare la merce ordinata entro i tempi previsti dalla casa o alle date concordate con il Cliente. La data di consegna ha tuttavia valore indicativo, quindi nessuna garanzia, né alcun indennizzo sono dovuti per mancata o ritardata consegna nei suddetti termini.

## TRASPORTO

La merce, anche se spedita franco destino, viaggia sempre per conto, rischio e pericolo del Committente. Ogni responsabilità della Falegnameria Serrana cessa al momento della consegna della merce al vettore. Sarà interesse del Committente verificare lo stato e la conformità della merce al momento del ritiro, avanzando eventuale reclamo secondo le modalità riportate nel punto seguente.



## ORDER ACCEPTANCE

Orders will be deemed to be accepted by the company Falegnameria Serrana snc only by means of an order confirmation, on basis of the sales terms stated herein. No other terms and conditions shall be binding. Changes in the quantities or specifications of the requested goods will be evaluated by the seller according to the state of progress of manufacturing. The buyer has to inform in writing the Sales Department about variations of the order.

## PRICE

This price list fully replaces any other previous price list. The prices are expressed in Euros and they are exclusive of costs of carriage, VAT and any other applicable sales tax or duty.

## VALIDITY OF THE INFORMATION

The company Falegnameria Serrana snc relentlessly pursues continuous improvement, therefore drawings, dimensions and finishings are subject to alteration without prior notice. Drawings and information given are

deemed valid, until updating occurs. While the company strives to provide accurate product information, pricing or typographical errors may occur. We take reservations on eventual typing-/printing errors.

## DELIVERY

The company Falegnameria Serrana snc will make a good effort to complete delivery of the goods as indicated by the company in writing, but the seller assumes no responsibility or liability and will grant no backcharge for loss or damage due to delay or inability to deliver.

## SHIPMENT

All risks linked to shipment shall be borne to the buyer. Before accepting delivery, the purchaser must check the condition of the packaging and immediately notify the carrier and the company Falegnameria Serrana snc of any damage or any problem which has emerged during transport. Written claims for defects or damages shall be initiated following the procedure described in the next point.

# CONDIZIONI DI VENDITA SALES TERMS AND CONDITIONS CONDITIONS GÉNÉRALES DE VENTE ALLGEMEINE GESCHÄFTSBEDINGUNGEN

## COMMANDE ET VALIDATION

Vous déclarez avoir pris connaissance et accepté les présentes Conditions générales de vente avant la validation de votre commande. La validation de votre commande vaut donc acceptation de ces Conditions générales de vente. Les commandes ne sont définitives que lorsqu'elles sont confirmées par Falegnameria Serrana. Toutes modifications doivent être notifiées par écrit au vendeur et à ses assujettis, au stade de fabrication.

## PRIX

La liste des prix de ce catalogue remplace toutes les listes précédentes. Les prix de ce catalogue remplace toutes les listes précédentes. Les prix sont indiqués en euros, hors TVA. Il s'agit de prix de détail.

## MODIFICATIONS AUX PRODUITS ET VALIDITÉ DE L'INFORMATION

Falegnameria Serrana poursuit une politique de constante amélioration du produit; par conséquent dessins, dimensions, finitions et prix sont indicatifs et on se réserve la faculté de modifications sans préavis. Les dates et les images de la liste des prix et sur toute la documentation

technique sont valables hors de faute dues à l'impression et hors de modifications faites par Falegnameria Serrana.

## CONDITIONS DE LIVRAISON

Falegnameria Serrana s'engage à livrer la marchandise commandée dans le temps prévu ou dans le temps convenu avec le client. La date de livraison est indicative et le vendeur n'assume aucune responsabilité pour les dommages ou retards en cours de transport.

## TRANSPORT

Le transport de la marchandise vers la destination de livraison s'effectue aux frais et risques de l'acheteur, même si elle est rendue franco destination. La responsabilité de Falegnameria Serrana cesse dès la prise en charge par le transporteur. Il incombe à l'acheteur de faire valoir ses droits envers les entreprises de transport lors de la réception de la marchandise. Vous devez notifier une réclamation, selon les indications suivantes.

## ANNAHME DER BESTELLUNG

Die Bestellung ist mit dem Empfang der schriftlichen Bestätigung der Fa. Falegnameria Serrana snc, dass die Bestellung angenommen wurde, abgeschlossen. Die Annahme der Bestellung erfolgt ausschließlich unter Anerkennung der nachstehenden Bedingungen.

Änderungen an bereits bestätigten Bestellungen müssen mit unserer Verkaufs-Abteilung überprüft werden. Jede vereinbarte Änderung oder Auflösung muss schriftlich erfolgen. Die Akzeptierung o.g. Änderungen hängt von der Bearbeitungsphase der Bestellung ab.

## PREIS

Diese Preisliste ersetzt alle vorher gültigen Preise. Alle Preise sind in EURO angegeben, ohne Mehrwerts-Steuer werden als Verkaufspreise zu betrachten. Sämtliche Nebenkosten gehen zu Lasten des Bestellers.

## GÜLTIGKEIT DER INFORMATIONEN

Veränderungen an Zeichnungen, Maßen und Bearbeitungen können aus

Verbesserungsgründen entstehen, ohne den Kunden im Voraus davon zu informieren. Die angeführten Informationen sind stets unverbindlich und vorbehaltlich Irrtümer, Änderungen und Druckfehler zu verstehen (Wir behalten uns jederzeit Änderungen der darin enthaltenen Angaben ausdrücklich vor).

## LIEFERUNG

Lieferung erfolgt ab Lager an die vom Besteller angegebene Lieferadresse. Angegebene Liefertermine sind unverbindlich und gelten nur als annähernd vereinbart.

## TRANSPORT

Der Transport der Ware erfolgt auf Kosten und Gefahr des Absenders. Für Transportschwierigkeiten jeder Art übernehmen wir keine Haftung. Der Käufer hat die Ware unverzüglich nach Übergabe zu untersuchen, soweit dies nach ordnungsgemäßigem Geschäftsgang möglich ist.

# CONDIZIONI DI VENDITA SALES TERMS AND CONDITIONS CONDITIONS GÉNÉRALES DE VENTE ALLGEMEINE GESCHÄFTSBEDINGUNGEN

## RECLAMI DA CLIENTE

**Non si accettano reclami sulla conformità del prodotto o smarrimento dello stesso, oltre 60gg dalla data di ricevimento merce.**

## GARANZIA E RESPONSABILITA' PER PRODOTTO DIFETTOSO

La Falegnameria Serrana garantisce il proprio prodotto come immune da vizi e difetti che lo rendono idoneo all'uso cui è destinato o ne diminuiscono in modo apprezzabile il valore; tale garanzia è subordinata alla corretta installazione, manutenzione ed all'uso appropriato dello stesso. Nel caso siano accertati nei tempi e secondo le modalità previsti\* i vizi, difetti o il mal funzionamento di cui ai punti precedenti, la Falegnameria Serrana si impegna, a sua insindacabile scelta, alla eliminazione e/o correzione e/o sostituzione delle parti difettose solo se le stesse siano imputabili al produttore. Nel caso in cui il prodotto non possa essere riparato o sostituito, la Falegnameria Serrana sarà tenuta al risarcimento del danno per un importo non superiore al prezzo dell'articolo venduto. Se il Committente verifica che al momento dello scarico della merce l'imballo è stato danneggiato, può accettare la stessa con riserva di verifica solo previa documentazione fotografica dello stato dell'imballo quando è ancora nel mezzo del trasportatore, per documentare che il danneggiamento dell'imballo è dovuto al trasporto e non si è verificato successivamente presso i locali del ricevente. Se, invece, l'imballo risulta integro, tuttavia, una volta rimosso, il Committente appura che il prodotto presenta vizi o difetti, eventuali contestazioni da parte sua devono essere documentate con prove fotografiche. In ogni caso, eventuali reclami devono essere fatti pervenire presso la sede della Falegnameria Serrana per mezzo fax, e-mail o lettera raccomandata non oltre l'ottavo giorno dal ricevimento della merce da parte del Committente. Se entro tale data

non viene presentato alcun reclamo, i prodotti si intenderanno accettati dall'Acquirente. Eventuali resi di merce devono essere preventivamente autorizzati per iscritto dalla Falegnameria Serrana.

## PAGAMENTO

Qualora venga concordato un pagamento dilazionato, i termini di pagamento sono da ritenersi essenziali, pertanto il mancato o ritardato pagamento comporta la decadenza del beneficio del termine ai sensi dell'art. 1186 c.c. dando facoltà all'altra parte di poter agire per il recupero dell'intero credito. Nell'ipotesi di ritardato pagamento, verranno addebitati al Committente gli interessi di mora nella misura del tasso ufficiale di sconto aumentato di 3 punti. Interessi di mora decorreranno dalla data di ricevimento del debitore di diffida inviata con raccomandata A/R. In caso di insoluto o comunque nel caso in cui la posizione commerciale del committente sia variata, anche a seguito di protesti elevati a suo carico, la Falegnameria Serrana si ritiene autorizzata a sospendere l'esecuzione delle forniture in corso o ad annullare i contratti con facoltà di rivalsa dei danni subiti. Qualsiasi contestazione non darà il diritto al Committente di ritardare o rifiutare il pagamento.

\* (La responsabilità del venditore opera per un periodo di 2 anni dal momento dell'acquisto, o meglio della avvenuta consegna. Il consumatore ha l'onere di comunicare al venditore l'esistenza del vizio o del difetto di conformità del bene entro 2 mesi dalla data della sua scoperta. La comunicazione non è necessaria solo se il venditore ha riconosciuto l'esistenza del difetto o l'ha nascosto. Di fatto, quindi, la garanzia opera per 26 mesi dalla data di acquisto.)



## CLAIMS

**The company Falegnameria Serrana snc does not accept claims about the conformity of the product or about the loss of it, over 60 days from the date of its receipt.**

## WARRANTY AND RESPONSIBILITY FOR DEFECTIVE PRODUCTS

The company Falegnameria Serrana snc guarantees its products against defective materials and or poor workmanship. This guarantee assumes correct use of the product by the purchaser and is therefore not applicable to eventual damage due to wrong installation, improper use or to negligence. In case that some defects or some malfunctions are detected,\* , the company Falegnameria Serrana snc, at its irrevocable option, will repair or replace the defective goods by only when found and proved defective for vice of material or manufacturing. The company will do that within the time and the way defined and in case that these defects or malfunctions belong to the above mentioned situations. If the product can't be replaced or repaired the refund will be limited to the price of the good stated on the invoice. The buyer shall inspect the goods immediately upon delivery. In case of any defect or damage to the good's packaging the buyer has to accept the product with reserve of control, putting a written notice on the driver's documents detailing in full the nature of the damage and the number of goods affected. A photographic proof of the goods in the deliver's means of transport will be needed to testify that the damage occurred during shipment and not at the buyer's premises. If, on the contrary, the packaging looks undamaged but the content is faulty the

buyer can initiate a claim contacting in writing the company Falegnameria Serrana snc. Claims must be accompanied by photographic proofs and must be sent by mail, fax or by a registered letter by priority post. If the buyer shall fail to so notify the seller, within 8 days after the goods have been received, such goods shall conclusively be deemed to conform to the terms and conditions thereof. No goods shall be returned without a prior company's authorization.

## PAYMENT

In case of delayed payment, the company reserves the right to charge interests at the Official Current Bank Rate (Prime Rate) increased by 3 points. Furthermore the company Falegnameria Serrana snc reserves the right to stop deliveries or cancel orders already accepted, when payments are not made within the fixed terms. All supplied goods are considered Falegnameria Serrana's Property until the whole amount due to Falegnameria Serrana snc, including any other relevant cost is paid off.

\* (The seller's responsibility is valid until 2 years, starting from the purchase, i.e. from the delivery. The buyer's responsibility is to inform the seller in case that a vice or a defect of material or a defect in the conformity of the goods is detected. This must be done within 2 months starting from the detection of the defect. This responsibility of the buyer isn't valid, if he has recognized the existence of the defect or if he has hidden it. This means that in fact the guarantee is valid for 26 months starting from the date of the purchase)

# CONDIZIONI DI VENDITA SALES TERMS AND CONDITIONS CONDITIONS GÉNÉRALES DE VENTE ALLGEMEINE GESCHÄFTSBEDINGUNGEN

## RÉCLAMATIONS DU CLIENT

**On n'accepte aucun réclamation sur la conformité du produit ou sur son perte, après plus de 60 jours dès la date de réception de la marchandise.**

## GARANTIE ET RESPONSABILITE' DU PRODUIT DEFECTUEU

Le vendeur est tenu de la garantie à raison des défauts cachés de la chose vendue qui la rendent impropre à l'usage auquel on la destine, ou qui diminuent tellement cet usage que l'acheteur ne l'aurait pas acquise, ou n'en aurait donné qu'un moindre prix, s'il les avait connus. La garantie du vendeur est limitée à la réparation, au remplacement ou à un remboursement en valeur des marchandises reconnues défectueuses par le vendeur, en tenant compte de l'usage qui en a été fait et ceci au libre choix du vendeur. Le remboursement s'effectuera exclusivement pour un montant identique à celui colis sont endommagés ou déjà ouvert émettre immédiatement des réserves écrites précises sur le bulletin de livraison du transporteur avec la photo des boîtes dans le camion du transporteur, comme preuve que la marchandise a été endommagée pendant son transport et pas après, chez le récepteur. En cas où l'emballage est intact mais après enlevé l'acheteur s'assure que le produit a des défauts ou des vices, il doit documenter ça avec des preuves photographiques. L'avis éventuel des défauts de la marchandise doit être adressé par écrit avec

une photo de la marchandise au vendeur dans un délai préemptoire de 8 jours dès la réception de la marchandise, faute de quoi la marchandise sera considérée comme acceptée. Tout retour de marchandise nécessite l'accord préalable de Falegnameria Serrana.

## PAIEMENT

Les ventes de produits sont payables dans le délai. Toute facture impayée à son échéance porte de plein droit et sans mise en demeure des intérêts moratoires au taux depuis sa date d' échéance plus 3 pointes . Tout défaut de paiement confère au vendeur le droit de résilier les commandes en cours. Le vendeur se réserve expressément la propriété des marchandises livrées et désignées ci après jusqu'au paiement intégral de leur prix. Le présent contrat est soumis à la loi italienne. En cas de litige les tribunaux de Ancona seront compétents.

\* ( La responsabilité du vendeur est valable pour 2 ans dès l'achat ou mieux dit dès la livraison au client. Le consommateur ha le fardeau de communiquer au vendeur l'existence de défauts et de vices de la marchandise dans 2 mois dès sa découverte. Cette communication ne se rend pas nécessaire dans le seul cas où le vendeur a reconnu l'existence du défaut ou l'a caché. Donc, en effet, la garantie est valable pour 26 mois dès la date de l'achat).

## KUNDENBEANSTANDUNGEN

**Die Firma Falegnameria Serrana snc akzeptiert keine Beanstandungen betreffs der Konformität des Produktes oder betreffs deren Verlust (auch zum Teil) , über 60 Tage nach Empfang der Ware.**

## GEWÄHRLEISTUNG

Für alle gelieferten Teile wird Gewährleistung in der Form übernommen, dass gelieferte Waren zum Zeitpunkt der Absendung frei von Material- und Herstellungsmängeln sind, die den Wert oder die Tauglichkeit der Ware erheblich mindern. Für Mängel oder Schäden, die durch ungeeignete oder unsachgemäße Verwendung, fehlerhafte Montage oder nachlässige Behandlung entstehen, wird keine Gewähr geleistet. Bei begründeter rechtzeitiger Rüge und nur wenn Materials- oder Herstellungsmängel nachgewiesen werden können ist die Firma unter Ausschluss aller anderen Ansprüche des Käufers zur Behebung des Mangels, zur Ersatz- oder Nachlieferung, nach ihrer Wahl verpflichtet. Soweit die Firma aufgrund grob fahrlässigen Verhaltens unserer Organe zum Schadensersatz verpflichtet sind, beschränkt sich der Anspruch auf Schadensersatz in Höhe des vereinbarten Verkaufspreis. Es werden keine Beanstandungen betreffs der Konformität des Produktes akzeptiert, nach 60 Tage ab Empfang der Ware. Falls der Auftraggeber bei Empfang der Ware einen Schaden an der Verpackung entdeckt, kann er die Ware mit Reserve deren Kontrolle annehmen, aber nur wenn der Zustand der Verpackungen durch Photos bewiesen wird und sich die Ware noch auf dem Transportmittel befindet. Damit wird bestätigt, dass der Schaden durch den Transport verursacht wurde und nicht nachher, durch dem Empfänger selbst. Falls die Verpackung auf keine Schäden hinweist, aber nach der Auspackung der empfangenen Ware der Auftraggeber feststellt, dass die Ware auf Laster und Mängel hinweist, müssen eventuelle Beanstandungen durch Photos bewiesen werden. Auf jeden Fall müssen die Beanstandungen schriftlich an die Firma Falegnameria Serrana snc per Fax, per E-Mail oder per versicherter

Brief zukommen, innert 8 Tage nach Empfang der Ware seitens des Auftraggebers. Falls innerhalb o.g. Frist keine Beanstandungen zukommen, wird die Ware als akzeptiert betrachtet. Eventuelle Rücknahmen der Ware müssen seitens der Firma Falegnameria Serrana snc schriftlich autorisiert werden. Die Zahlungstermine sind einzuhalten. Hält der Besteller die vereinbarten Zahlungstermine nicht ein, so hat er ohne Mahnung vom Zeitpunkt der vereinbarten Fälligkeit an Zinsen von 3 Punkten über dem jeweiligen Diskontsatz der Banca Italiana zu entrichten. Ist der Besteller mit einer Zahlung aus irgendeinem Grund im Rückstand, oder muss der Lieferant aufgrund eines nach Vertragsabschluss eingetretenen Umstandes ernstlich befürchten, die Zahlungen des Bestellers nicht vollständig oder rechtzeitig zu erhalten, ist der Lieferant ohne Einschränkung seiner gesetzlichen Rechte befugt, versandbereite Lieferungen zurückzubehalten, dies, bis neue Zahlungs- und Lieferbedingungen vereinbart sind. Falls der Lieferant keine genügenden Sicherheiten erhält, ist er berechtigt, vom Vertrag zurückzutreten und Schadensersatz zu verlangen.

## EIGENTUMSVORBEHALT

Der Lieferant bleibt Eigentümer seiner gesamten Lieferungen, bis er die Zahlungen gemäss Vertrag vollständig erhalten hat.

## GERICHTSSTAND

Gerichtsstand ist Ancona. Auf die Vertragsbeziehung ist ausschließliche das italienische Recht anzuwenden.

\* Die Verantwortlichkeit des Verkäufers gilt 2 Jahre, ab Einkauf der Ware, d.h. ab deren Anlieferung. Der Verbraucher hat die Pflicht, dem Verkäufer die Laster und die Mängel an der Konformität bekannt zu geben, innert 2 Monate ab deren Feststellung. Die Bekanntgabe ist nur dann nicht notwendig, wenn der Verkäufer den Mangel anerkannt hat, oder es versteckt hat. In der Tat ist die Gewährleistung 26 Monate ab Einkaufsdatum gültig.

# SCHEDA CLIENTE

CUSTOMER SHEET  
FICHE CLIENT  
KUNDEN- DATENBLATT

DATA \_\_\_\_\_  
Date

RAGIONE SOCIALE \_\_\_\_\_  
Business name

AMMINISTRATORE/LEGALE RAPPRESENTANTE \_\_\_\_\_  
Aministrator /Legal representative

CATEGORIA MERCEOLOGICA \_\_\_\_\_  
Product category

SEDE \_\_\_\_\_ C.A.P. \_\_\_\_\_  
Postal code of the headquarters postal code

CITTÀ \_\_\_\_\_ PROV \_\_\_\_\_  
Town

TEL \_\_\_\_\_ CEL \_\_\_\_\_ FAX \_\_\_\_\_  
Phone number Mobile Fax

SITO WEB \_\_\_\_\_  
Web-site

COD. FISCALE \_\_\_\_\_ P. IVA \_\_\_\_\_  
Tax code

RESPONSABILE \_\_\_\_\_ TEL. \_\_\_\_\_ E-MAIL \_\_\_\_\_  
Responsible Phone number E-mail

E-MAIL [comunicazioni commerciali] \_\_\_\_\_  
E-mail [for commercial communications]

E-MAIL [amministrazione] \_\_\_\_\_  
E-mail [administration department]

E-MAIL [gestione ordini] \_\_\_\_\_  
E-mail [purchase department]

E-MAIL [PEC] \_\_\_\_\_  
E-mail [certified]

LUOGO DI CONSEGNA \_\_\_\_\_  
Delivery address

PRESSO \_\_\_\_\_  
At

LOCALITÀ \_\_\_\_\_ C.A.P. \_\_\_\_\_  
Postal code

CITTÀ \_\_\_\_\_ PROV \_\_\_\_\_  
Town

TEL \_\_\_\_\_ FAX \_\_\_\_\_  
Phone number Fax

SEGNALAZIONI UTILI ALLO SCARICO \_\_\_\_\_  
Information useful for the delivery

\*Con riferimento alla legge N°675/96 comunichiamo che i suoi dati verranno utilizzati esclusivamente da noi per l'invio di comunicazioni commerciali. Qualora lo ritenga, potrà chiedere la cancellazione dei suoi dati in nostro possesso o l'interruzione dell'invio di ulteriori comunicazioni.

\*With reference to the law which regulates the privacy, we inform you that your data will be used by us for commercial communications only. If you want, you can ask us to cancel the data that we hold or you can ask us to stop the communications.











# EVOLINE<sup>3</sup>

— FALEGNAMERIA SERRANA —

